

DOOR COMMUNICATOR

# Fores VarioBell



**User manual v 1.1**

## Compatibility of Fores VarioBell with A-VarioBell

1. Same dimensions and design – same mechanical parts (boxes, rainhoods, etc.)
2. Same button modules and keypads
3. the same USBKAB USB cable can be used for programming
4. the new ForesSet setup software also supports the A-VarioBell
5. the same configuration file as the A-VarioBell
6. Simplified set of commands
7. Tone selection only
8. Potentiometer for adjusting the volume
9. Potentiometer for adjusting microphone sensitivity



Version 1.2

Alphatech, spol. s r. o.

Jeremenkova 88

140 00 Prague 4, Czech Republic

Tel: 244 461 072

[www.alphatech.cz](http://www.alphatech.cz) / [info@alphatech.cz](mailto:info@alphatech.cz)

# Content

---

<b>1</b>	<b>BASIC DESCRIPTION.....</b>	<b>4</b>
1.1	PROPERTIES .....	4
1.2	FORES VARIOBELL SETS.....	6
1.2.1	<i>Expansion modules</i> .....	6
1.2.2	<i>Mechanical Parts</i> .....	7
1.3	DESCRIPTION OF THE BASIC MODULE .....	10
1.4	CONNECTING THE EXPANSION MODULES VBD10(5) -MOD .....	14
1.4.1	<i>Example of connecting VBD10-mod modules</i> .....	15
1.4.2	<i>Example of connecting VBD5-mod modules</i> .....	16
1.4.3	<i>Button numbering</i> .....	18
1.5	CONNECTING THE VBDKEY KEYBOARD.....	20
1.6	SIGNALING ON THE FRONT PANEL OF THE BASE MODULE .....	21
<b>2</b>	<b>INSTALLATION .....</b>	<b>22</b>
2.1	ASSEMBLY .....	22
2.2	CONNECTION .....	24
2.3	OTHER ACCESSORIES .....	26
2.3.1	<i>12 V power supply</i> .....	26
2.3.2	<i>USB programming cable</i> .....	26
<b>3</b>	<b>OPERATION OF THE FORES VARIOBELL .....</b>	<b>27</b>
3.1	SIGNALING OVERVIEW .....	27
3.2	OUTGOING CALL .....	28
3.3	RELAY MODES.....	29
3.4	INCOMING CALL .....	30
3.4.1	<i>Door communicator with keyboard – VBDKey module</i> .....	31
<b>4</b>	<b>PARAMETER PROGRAMMING.....</b>	<b>32</b>
4.1	PROGRAMMING WITH YOUR PHONE.....	32
4.1.1	<i>Entry into programming</i> .....	32
4.1.2	<i>Parameter programming</i> .....	32
4.2	PROGRAMMING FROM A PC – FORESSET .....	33
<b>5</b>	<b>DESCRIPTION OF CONFIGURATION PARAMETERS.....</b>	<b>34</b>
5.1	DIRECT SELECTION OF NUMBERS – MEMORIES .....	34
5.2	RELAYS.....	36
5.3	BASIC PARAMETERS.....	40
5.4	TIME PARAMETERS.....	43
5.5	SYSTEM PARAMETERS.....	45
5.6	HANDSFREE SETUP.....	47
5.7	BASIC SETTINGS AND DELETION.....	47
5.8	END OF PROGRAMMING.....	47

5.9	OVERVIEW OF PARAMETERS .....	48
<b>6</b>	<b>TECHNICAL PARAMETERS.....</b>	<b>51</b>
6.1	ELECTRICAL PARAMETERS .....	51
6.2	MECHANICAL DIMENSIONS .....	51

# 1 **Basic description**

---

## 1.1 **Properties**

- Tone dialing (pulse dialing is no longer supported)
- Two phone numbers for each button, two numbers in series or Day/Night mode
- The maximum number of buttons in the assembly is 87
- Switching Day/Night by DTMF Code
- Extend a call by selecting \* or #
- Optional call ticking for call resolution
- Baby call in conjunction with PBX function
- Two codes to hang up the door communicator from the phone
- End the call by pressing the same button again
  
- Two relays powered from an external 12 V source with a switching contact, e.g. for opening doors
- For each relay 2 codes to open the door from the phone called
- Up to 6 codes for external code opening for each relay
- Function of the exit button for opening the door when leaving the building
- Optional acoustic relay switching signaling (for silent locks)
  
- Selectable number of rings before picking up an incoming call
- Adjustable tone dialing parameters
- Adjustable acoustic signaling parameters
- Adjustable Tone Detector Parameters
  
- Multiple levels of factory settings
- programming via DTMF or via a special USB cable from a personal computer
- Integrated heating for outdoor installation
- Switchable name shield illumination
- grounding outlet for better protection against static electricity



The manufacturer continuously improves the firmware of the product. The latest firmware version from <http://www.alphatech.cz> can be loaded into the door communicator using the ForesSet program and a special USB cable.

## 1.2 Fores VarioBell Sets

**Fores VBD-xx basic module** – Fores VarioBell basic module is equipped with two buttons (Fores VBD-02), one button (Fores VBD-01) or no button (Fores VBD-00).



Basic module  
Fores VBD-02



Basic module  
Fores VBD-01



Basic module  
Fores VBD-00

### 1.2.1 Expansion modules

**Button modules VBDx-mod:**

- VBD5-mod is a module with five buttons
- VBD10-mod is a module with ten buttons

The numbering of buttons does not depend on the connection of the modules and is set using the DIP switch on each module (see below).

**Keyboard VBDKey** – the keyboard connection does not need to be configured in any way and does not depend on the connection location (see below).

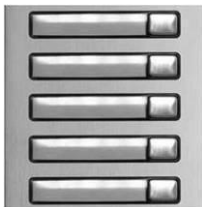

Button module  
VBD5-mod

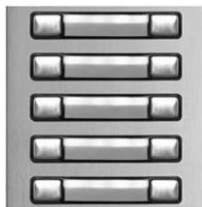

Button module  
VBD10-mod

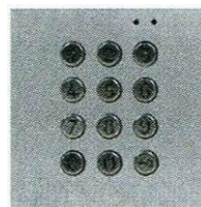

Keyboard  
VBDKey

### **1.2.2 Mechanical Parts**

For simplicity, the mechanical parts for 1, 2 and 3 modules are shown here. There are a maximum of 3 modules in a column, a large assembly contains a maximum of 3 columns (9 modules). For even larger assemblies, blocks of 9 modules can be stacked on top of or next to each other

#### **Flush-mounted mounting boxes:**



Mounting box-1



Mounting box-2



Mounting box-3

**Fastening and cover frame** – for under- and surface-mounted installation



for 1 module



for 2 modules

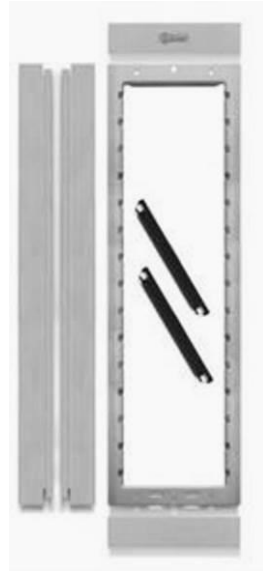

for 3 modules

**Edge frame** – for flush mounting



Frame-1



Frame-2



Frame-3

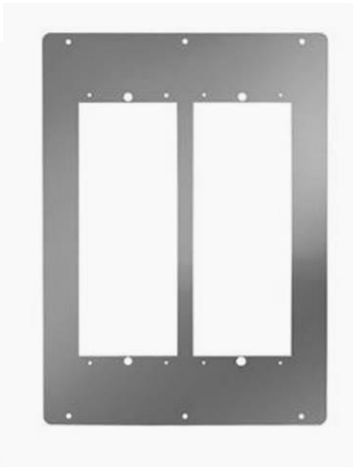

Frame - 3 x 2

**Rainhood** – for flush mounting



Rainhood-1



Rainhood-2



Rainhood -2 x 2

**KPD – Box with integrated rainhood** – for flush mounting (frames shown are separate)



KPD-1



KPD-2



KPD-3

### 1.3 Description of the basic module

All functional and connecting elements are marked with a number. The explanation is on the next page.

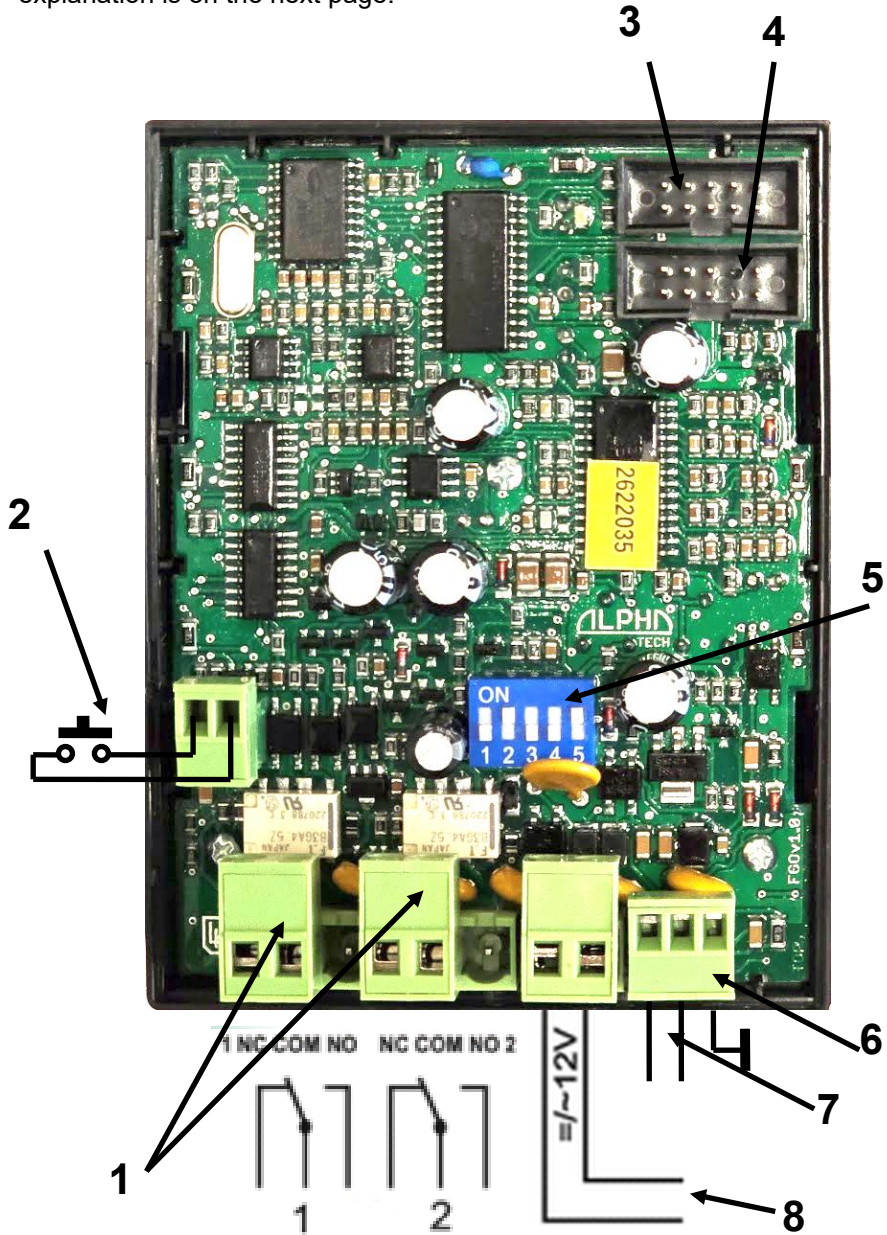
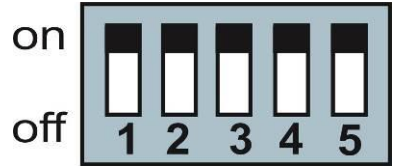
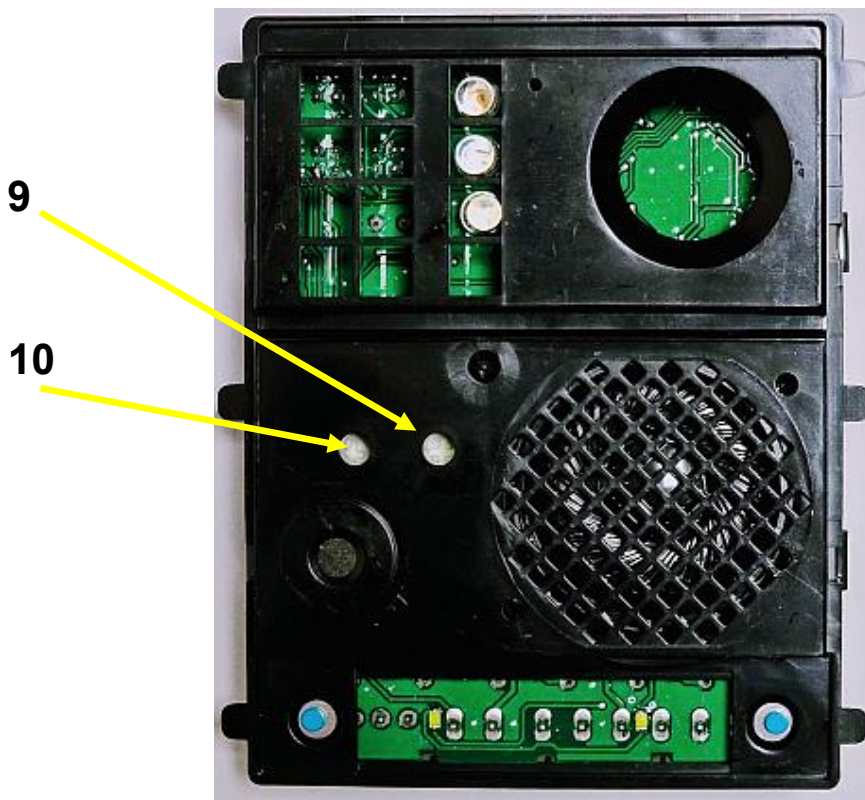

Fig. 1 Basic module of the Fores VarioBell

1. **Two relays** – galvanically isolated switching contacts, load is max. 48V, max. 1.5A
  2. **Exit button** – Used to switch the relay when leaving the building. Connect only a switching contact. Using power supply – see (8) – is required.
  3. Connector for **connecting to a PC** via USB cable
  4. Bus connector for **connecting** button and keyboard modules
  5. **DIP Switch:**
    - 1 = Service – incoming call starts directly programming mode. Use if the password is not known. For normal operation, it must be in the OFF position.
    - 2 = Heating – switches on the integrated heating of the plate to prevent condensation of moisture during temperature changes
    - 3, 4 Always leave in the OFF position
    - 5 = Name shield backlight
  6. **Grounding** – connection to the ground against static electricity – protects the electronics of the door communicator and the telephone exchange
  7. Analog **telephone line** (polarity does not matter)
  8. **External Power Source** It is used to power for:
    - Relay control
    - Heating Plates
    - Name shield backlight
    - Power supply of the exit button circuit
- If none of these features are used, the resource is not needed.





**Fig. 2: Front side of the Fores VarioBell door communicator**

- 9. Potentiometer for adjusting the **speaker volume**
- 10. Potentiometer for adjusting **microphone sensitivity**

**External Power Source (8):**

Standard DC power supply 12 V=, alternatively up to 24 V=. Polarity doesn't matter. For 12 V= the max. consumption is 250 mA. The power supply can also be used to power the lock, then a 12 V=/1 A power supply is recommended

Alternatively, it is also possible to use an AC power supply of 12 V~.

**Exit button (2):**

The exit button is used to control the relay. Each relay can be set to switch to one or two pulses. The button (10) is connected to the circuit of the current loop powered by an external source (6). In this way, the exit button can be connected with a cable up to 500 m long.

**Button Expansion Bus (4):**

The bus cable also supplies power for the name tag backlight on the modules. The bus allows you to connect expansion modules with up to 85 buttons including the keyboard. Together with the basic module, the entire assembly can have a maximum of 87 buttons.

The button module is available in two versions:

**VBD5-mod** has 5 buttons on the right

**VBD10-mod** has 10 buttons - 5 on the right and 5 on the left

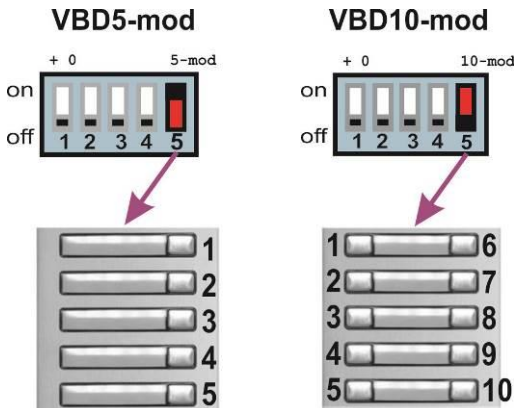

The **VBDKey** keyboard can be placed anywhere on the bus and is automatically detected.

## 1.4 Connecting the expansion modules VBD10(5) -mod

The button expansion modules are **VBD10-mod** with ten buttons and **VBD5-mod** with five buttons. The modules can be connected as needed, the numbering order is NOT affected, as it is set on each button module using the DIP switch (6).

The VBDx-mod electronics board is connected to the VarioBell button module mechanics only using the terminal block (5) and the cable (4). The connector (7) is not used in the analog version.

The connection is made using K1 ribbon cables. (1) is the connection to the basic module, (2) is the connection to the next button module, (3) is the connection from the previous button module (still the same K1 ribbon cable)

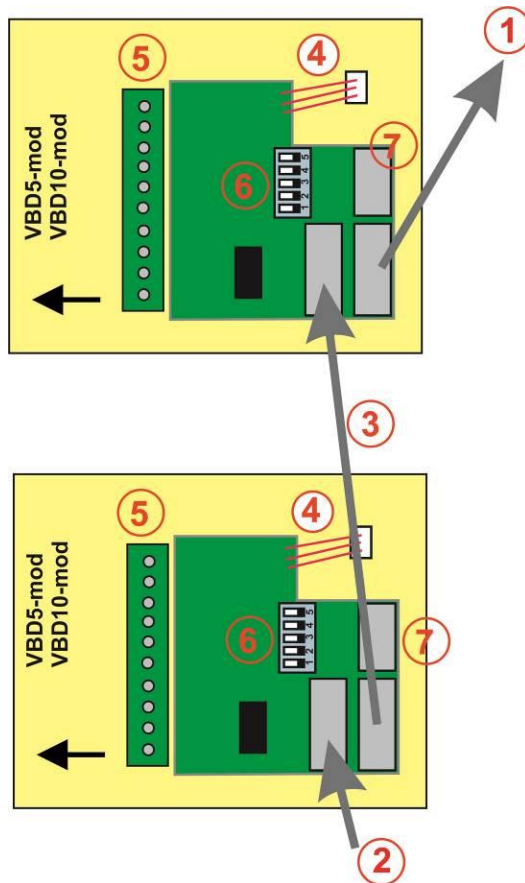

Fig. 2 VBD10-mod and VBD5-mod interconnection

### 1.4.1 Example of connecting VBD10-mod modules

The connection is made using a flat cable K1. In the example, a basic module with two buttons is used (programmable parameter **6#** = 2 see page.47) and the VBDKey keyboard module is also used in the connection. The numbering of the modules is set using the DIP switches (**6**) always shown next to the respective module. The corresponding button numbers are in the left column. The keyboard module is detected automatically and no settings are required, it can be connected anywhere. The button numbering remains unchanged (given by the DIP switches on the respective module) regardless of the order in which the modules are connected.

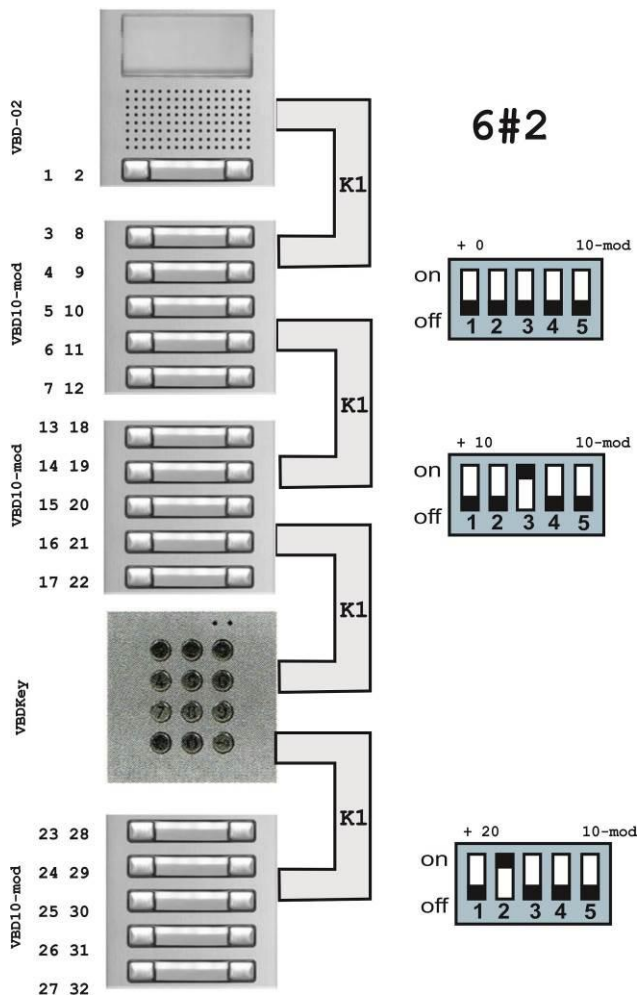

Fig. 3 Connecting Fores VarioBell with VBD10-mod

## 1.4.2 Example of connecting VBD5-mod modules

The connection is made using a flat cable K1. In the example, a basic module with one button is used (programmable parameter **6#** = 1 see page.47) and the VBDKey keyboard module is also used in the connection. The numbering of the modules is set using the DIP switches (**6**) always shown next to the respective module. The corresponding button numbers are in the left column. The keyboard module is detected automatically and no settings are required, it can be connected anywhere. The button numbering remains unchanged (given by the DIP switches on the respective module) regardless of the order in which the modules are connected.

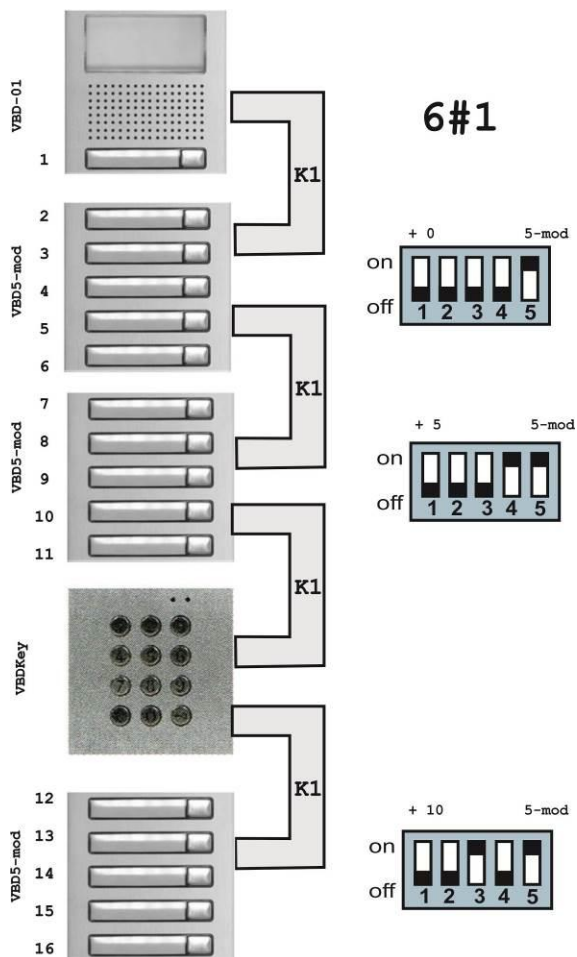

Fig. 4 Connecting Fores VarioBell with VBD5-mod

### 1.4.3 Button numbering

The numbering of buttons **depends on** two settings:

1. Number of buttons on the basic panel – parameter **6#** - see page.47.
2. DIP switch settings on each button module

The numbering **does not depend on** the method (order) of connecting individual button modules.

**The constant 6#** = [0-1-2] set in the basic module determines how many buttons the front panel of the basic module has. This affects the numbering of buttons as a numbering shift, i.e. this constant is added to the set button number.

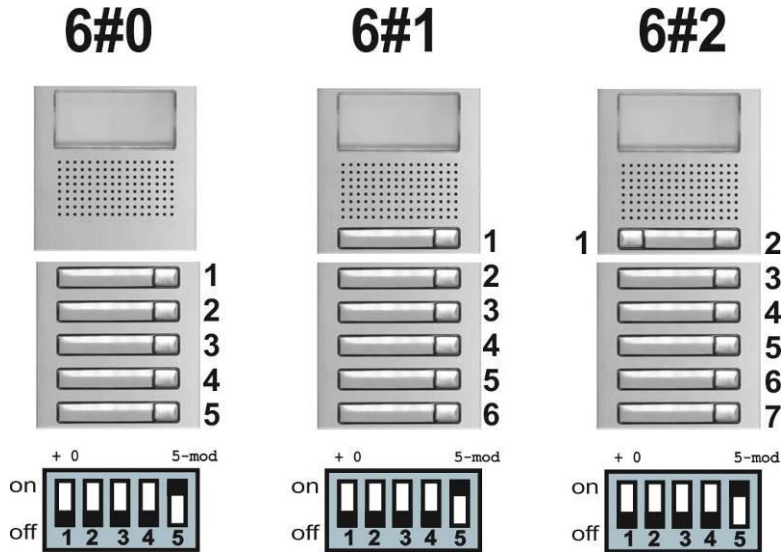

As can be seen in the figure, the DIP switch settings of the button module are still the same, but the number of the first button of the VBD5mod button module changes from 1 to 3 according to the setting of parameter **6#**.

#### DIP switch (6) setting on the button module.

The individual DIP switches have the following meaning:

**DIP 1–4** = setting the number of previous buttons of the button modules (not including the basic module)

**DIP 5** = setting the module itself, i.e. whether it's front panel has 5 or 10 visible buttons

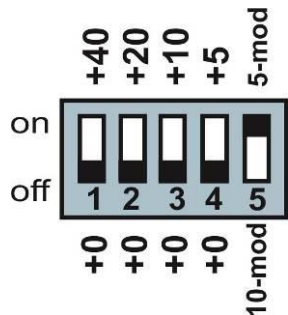

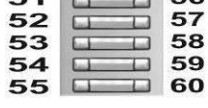
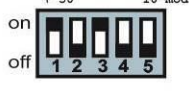
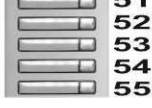
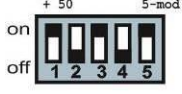
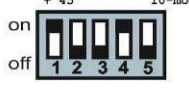
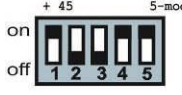
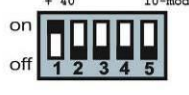
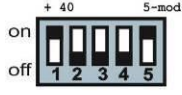
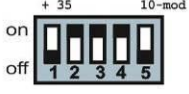
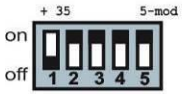
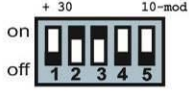
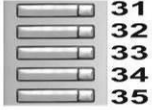
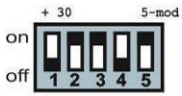
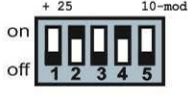
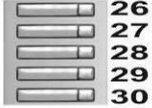
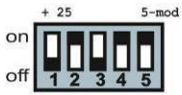
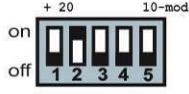
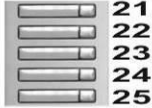
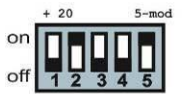
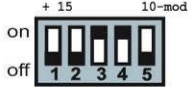
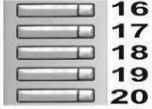
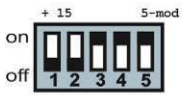
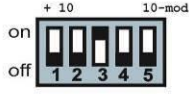
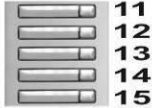
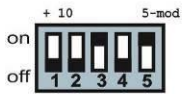
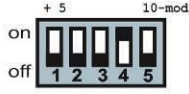
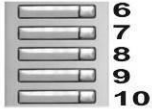
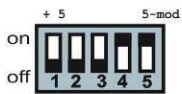
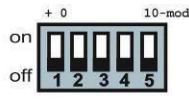
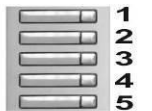
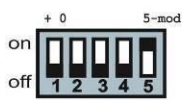

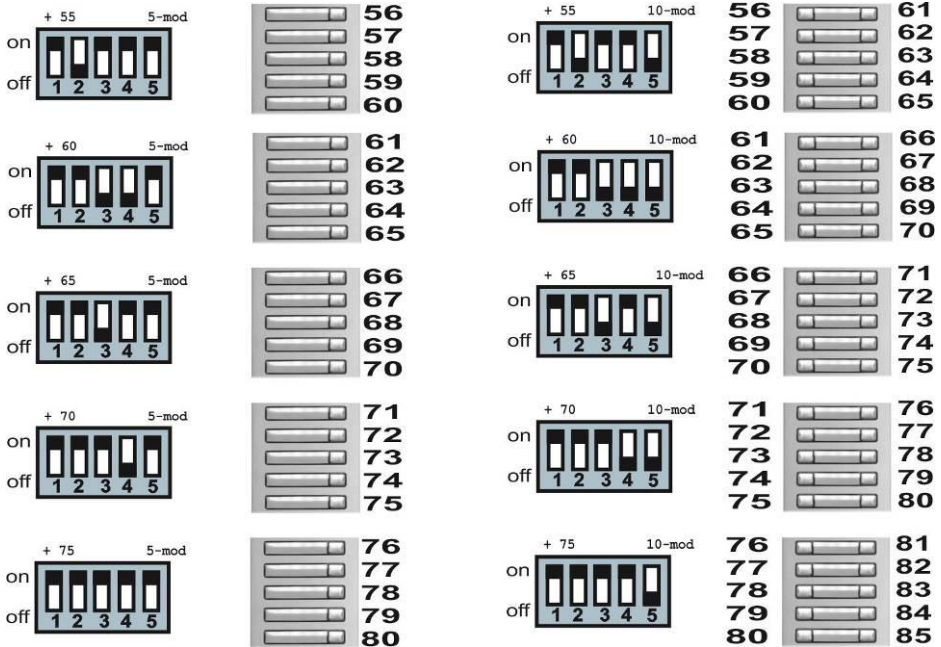

The numbering of the modules is shown in the picture, on the left are modules with 5 buttons VBD5-mod and on the right are modules with 10 buttons VBD10-mod.

Find the module with the required numbering in the picture - on the left next to it is the DIP switch combination (**6**) that you need to set on the module.



The numbering is independent of how the modules are connected by K1 cables.



If you connect two button modules with the same DIP switch settings to the system, nothing will happen, but both modules will have the same button numbers and therefore the same function.



No need to configure anything for the keyboard module.



If you connect two keyboards to the system, both will be functional and have the same function.

## 1.5 Connecting the VBDKey keyboard

The keyboard module is connected with a flat cable in the same way as the VBD10(5)-mod modules

The connection is made using flat cables K1. (1) is the connection towards the basic module, (2) is the connection to the following button module.

The connector (7) is not used in the analog version of the Fores VarioBell.

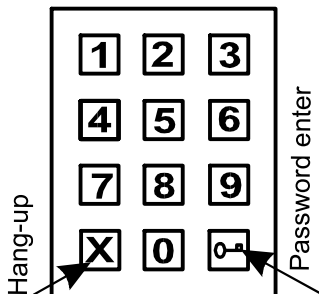
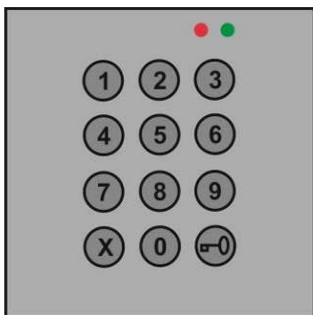
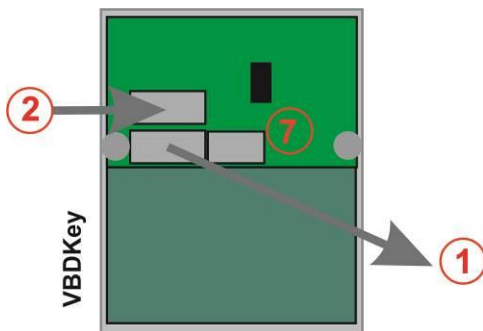



The telephone number or memory number is entered by pressing the digits one by one. To enter the entry password, the key symbol button must be pressed first. To hang up, you can press X at any time and the door communicator will hang up or cancel the number entry process.

The code lock can be controlled using the keyboard after pressing the key symbol, or by pressing a combination of the first ten buttons (buttons 1-10, where button 10 = is understood as 0).

**The keyboard** has two basic modes for dialing telephone numbers (parameter 49).

- Direct dialing of phone numbers – numbers are dialed on the keyboard as on a telephone (max. 24 characters)
- Dialing numbers from the memory – on the keyboard, only a two-digit number is entered = memory address (01-99). This method saves the number of connected button modules. For multiple subscribers, it is more convenient to use several buttons for direct dial and a keyboard in memory dialing mode than to create a huge set of button panels.

*Note: Button 1 on the base panel addresses the same phone number memory as dialing on the keypad 01 etc. up to 87, memories 88 to 99 are only accessible from the keypad.*

Parameter **40** allows you to set the option to dial DTMF during a call. Because the button  on the keyboard is used exclusively for hanging up and canceling the code entry, the value of parameter **40** also determines whether the button  will serve as \* or # during a call.



No need to configure anything for the keyboard module



If you connect two keyboards to the system, both will have the same function.

## 1.6 Signaling on the front panel of the base module

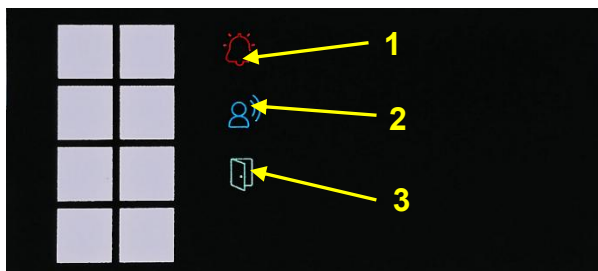

The Fores VarioBell allows the status of the door communicator to be signaled on the front panel. This is usually used for deaf visitors.

- Bell symbol **(1)** - red LED flashes when the Fores VarioBell rings.
- Person symbol **(2)** - blue LED flashes when a connection is established and you can speak (Call)
- Door symbol **(3)** - green LED lights up as long as at least one of the two relays is activated (Door opening).
- An induction loop for attaching a hearing aid is optionally located under the “deaf” symbol



**Attention! The signaling is functional only when a 12V power supply is connected!**

## 2 Installation

### 2.1 Assembly

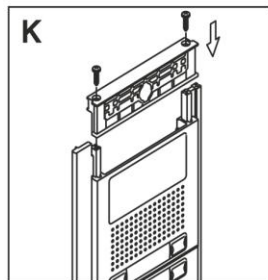
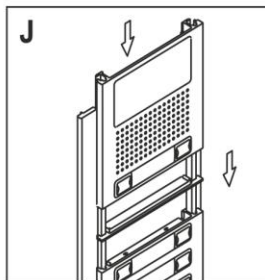
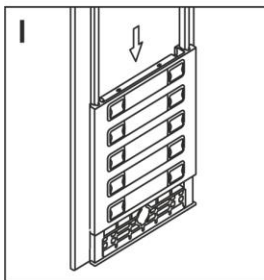
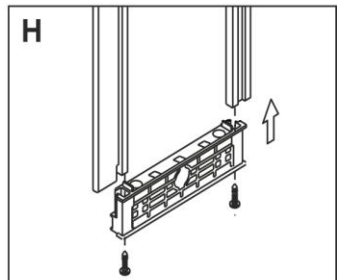
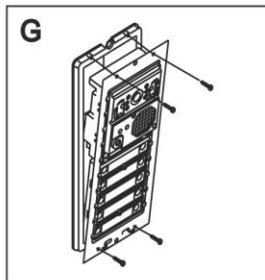
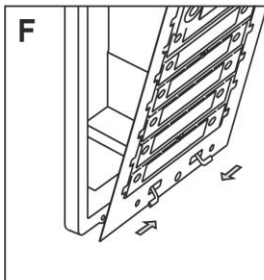
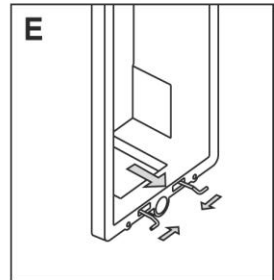
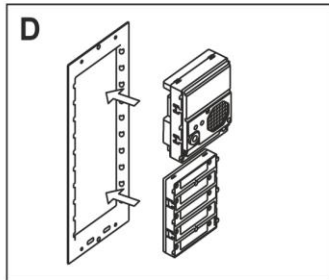
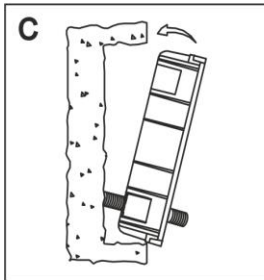
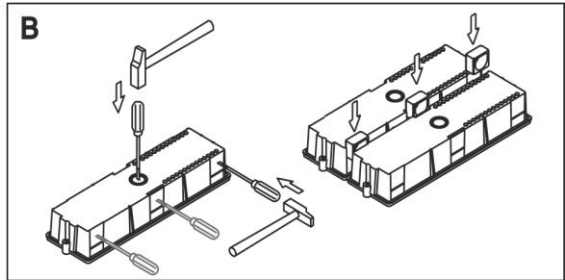
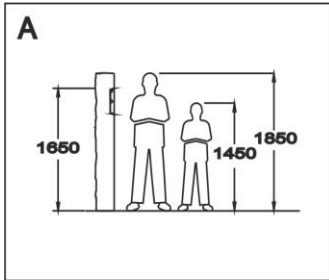

**Assembly procedure:**

- A. Preparing the mounting hole in the wall – the recommended height of the top edge is around 160cm from the ground. The size of the hole depends on the number of modules. Here are the approximate dimensions for 1, 2 and 3 modules (basic mounting boxes). For larger sets, the assembly consists of these mounting boxes arranged side by side and below each other.

No. of modules	1	2	3
Height [mm]	140	257	374
Width [mm]	125	125	125
Depth [mm]	56	56	56

- B. Preparing the mounting box for cables and interconnecting the mounting boxes
- C. Fitting the mounting box(es) into the wall opening
- D. Inserting individual modules into the mounting frame
- E. Fitting the spring into the bottom of the mechanical box
- F. Attaching the mounting frame to the spring in the mounting box
- G. Mounting the mounting frame to the mounting box using 4 screws (part of the mechanism)
- H. Assembly of the edge frame – first screw the side panels to the bottom part
- I. Insert the front panels of the individual modules into the edge frame
- J. The last module (the one at the top) is inserted into the edge frame
- K. The upper part of the edge frame is screwed to the side panels.
- L. Insert the assembly according to the pictures (H+I+J+K) into the next mounting box.
- M. Finally, the covers are placed on the edge frame.

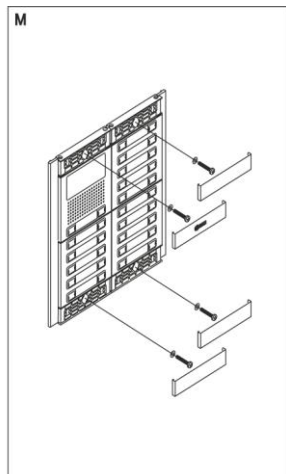
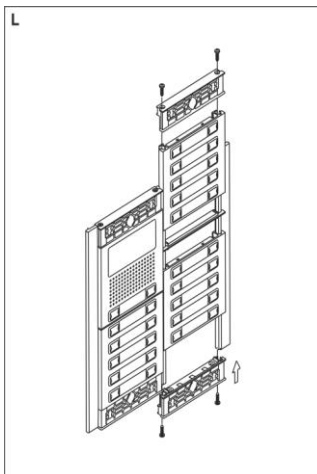

## 2.2 Connection

The basic function (making and receiving calls) requires only the connection of a **telephone line** – LINE (7) in Fig. 1. The phone line is galvanically isolated from the power supply and relay contacts. This arrangement prevents problems with leakage currents and mutual interference.

The line is connected with 2 wires (a, b) and when on-hook, it usually has a voltage of 24 V – 60 V, a short-circuit current of 20 mA – 60 mA. When the line is picked up, the line voltage is 7 V – 10 V.

The Fores Vario door communicator will announce the **connection to the line** audible signal (Reset) ♪ (Chapter 3.1 Pg. 27) if it has been disconnected from the line for a sufficient period of time. The door communicator is designed for connection to an analog telephone line, i.e. one on which a standard analog telephone operates. It works regardless of the polarity of the telephone line and within the range of values specified in the technical parameters (chapter 6).

**Parallel connection** and various devices switching the line – intelligent splitters, double splitters, etc. are not recommended for normal operation. They can only be used for service operations.

To control relay, board heating, name shields backlight, and for the the exit button function it is necessary to connect **External Source (8)** -see pg. 10.

The **relay (1)** contacts -

Fig. 1 are galvanically isolated, both from the external source and from the telephone line. They can switch a voltage of max. 48 V.



**In no case may the mains voltage of 230 V or 120 V be switched directly!!!** The need to control mains appliances must be solved by contactors.

**Examples of use** are on the next page, they are far from all the options for wiring and connecting relays, but they give instructions on how to connect individual circuits (red circles with numbers = example numbers).

1. Basic connection - 2 electric locks and the ability to control two doors independently (relay 1 and 2 mode  $m = 1$ ) or gradual door opening (relay mode 2 -  $m = 5$ ).
2. Two power supplies – the ability to use two power supplies independently, one for Fores Vario and the other for electric locks. Electric lock 2 is connected inverted (fire escape door).
3. Combination of doors with electric locks and a sliding gate in the fence.
4. Combination of electric lock and additional doorbell. The relay of the additional doorbell can be in mode  $m=4$  (switches on by any button for a set time) or in the  $m=6$  mode (switches on by a one preset button for a set time)

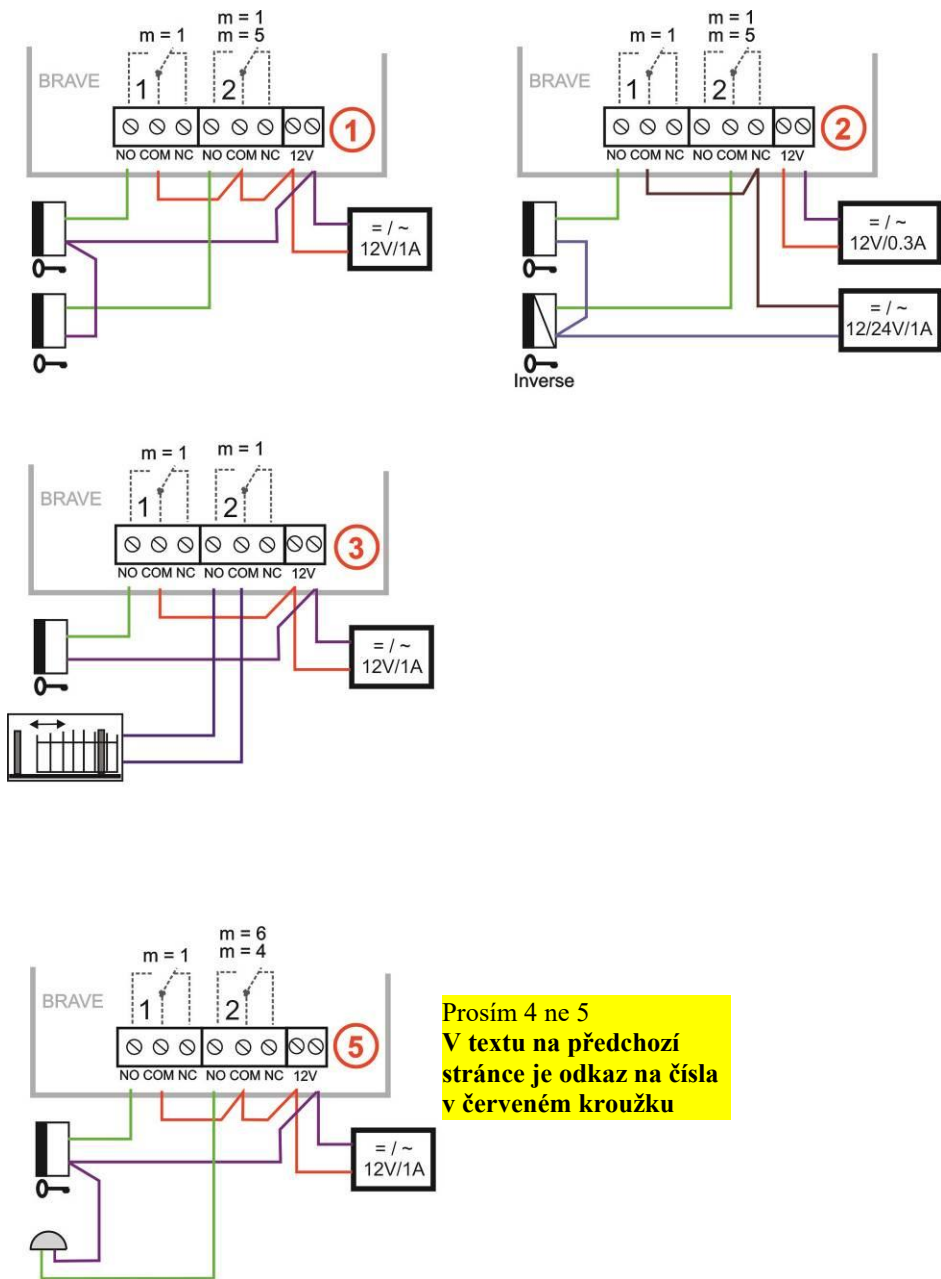

Fig. 5 Examples of relay wiring

## 2.3 Other accessories

### 2.3.1 12 V power supply

As an option, the Fores VarioBell comes with a 12 V/1 A AC power supply. Not included, must be ordered separately. You can find more about power supplies and electric locks at [www.alphatech.cz](http://www.alphatech.cz).



### 2.3.2 USB programming cable

The USBKAB USB cable is the same as for Brave series door communicators or elevator communicators. The USB driver is on the website [www.alphatech.cz](http://www.alphatech.cz). The driver is not electronically signed and therefore it is necessary to install it according to the instructions at [www.alphatech.cz](http://www.alphatech.cz).



## 3 Operation of the Fores VarioBell

### 3.1 Signaling overview

The Fores VarioBell door communicator acoustically signals conditions that may occur during operation. For easier recognition, it's usually used one tone combination of different lengths as in Morse code.

Status	Signaling	Comment
Connecting to a Line (Reset)		Morse "K"
Line pick up ( OFF HOOK) type 1		Morse "A"
Line hang up ( ON HOOK) type 1		Morse "N"
Line pick up ( OFF HOOK) type 2		Morse "U"
Line hang up ( ON HOOK) type 2		Morse "D"
Memory empty (no number programmed)		Morse "H"
Knocking into a call		Very short beeps
Call end notification		Morse "S"
Programming mode entered		4 commas (Morse Ch)
Programming mode prompt		Two modulated beeps
Command or parameter accepted		Very long comma
Command or parameter rejected		Morse "5"
Line connection (Reset)		Modulated signal

The activity of the device can be analyzed by the tones it plays. This can be useful for installation problems or failure behavior analysis. Sound signaling can be set using parameters 61, 62 and 63.

## 3.2 Outgoing call

After pressing the button, the door communicator picks up the line, plays the line pick-up signal (unless disabled by par. **62**) and dials the subscriber's telephone number assigned to the button. A ringing tone is heard from the loudspeaker. As soon as the callee picks up, he can talk to the visitor at the door. If an electric lock is connected to the door communicator, the callee can open the door for the visitor by dialing the DTMF code on his telephone. If he hangs up the telephone, the door communicator will also hang up after detecting a busy tone. If the call lasts longer than the set limit (parameter **52**), 15 seconds before hanging up, the door communicator will send a signal notifying the approaching end of the call. If the callee dials \* or # on his telephone according to the settings (parameter **42**), the call will be extended again by the time set by parameter **52**. The dialed number differs depending on the dialing mode set (parameter **47**):









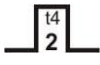
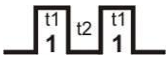
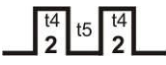

1. **Day/Night mode** = if the door communicator is in Day mode, it always dials the number set in parameter **1xx**, if it is in Night mode, it always dials the number set in parameter **2xx**. Switching modes manually is set by parameters **45, 46**.
2. **Two groups of numbers mode** = first press of the button – it always dials the number set in parameter **1xx**, when the same button is pressed again, or when a busy tone is detected 10 seconds after dialing, or after the set number of rings (parameter **56**) has elapsed, the door communicator dials a number from the second group (parameter **2xx**). When the same button is pressed again, the number from the first group is dialed again, etc. (after detecting a busy tone after dialing a number from the 2nd group, the repetition ends)

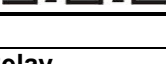

If the visitor presses the button after picking up the door communicator, the door communicator hangs up for the time specified by parameter **54**, picks up the line again and dials a new number. The number is dialed using tone dialing (DTMF). The call on the door communicator side can be ended prematurely by pressing the same button again, if this is set (parameter **4\***).

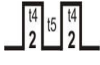
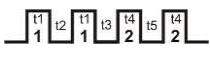
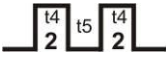
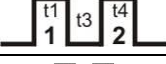
Using buttons 1 to 10, it's possible to control the relay (i.e. **unlock the locks**). If the visitor at the door presses the buttons one after the other so that the combination corresponds to the programmed external code (parameter **32-34**) and the time between pressing the individual buttons is not greater than the set time (parameter **53**), the door communicator will pick up, switch on the relevant relay (if set in mode  $m=1$  or  $m=5$ ) for the time given by parameter **37** or **39, 30**. And finally hang up again.

The relay can switch on one pulse or two pulses with the time between pulses set by parameter **30**, see Tab. 1 on next page.

### 3.3 Relay Modes

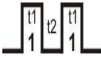
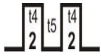
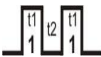
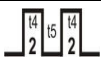
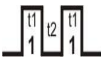
<b>Mode m = 1</b> (parameter 3111 and 3121)			
<b>Events</b>	<b>Note</b>	<b>Parameter</b>	<b>Relay</b>
<b>External code entered from buttons</b>	Always valid	3211-3215	
	Valid for DAY	3311-3315	
	Valid for NOC	3411-3415	
	Always valid	3221-3225	
	Valid for DAY	3321-3325	
	Valid for NOC	3421-3425	
	Always valid	321*	
	Valid for DAY	331*	
	Valid for NOC	341*	
	Always valid	322*	
Valid for DAY	332*		
Valid for NOC	342*		
<b>Internal code entered on the phone</b>	You can choose 1 or 2 digits of the code The 2-digit code is basic and can be abbreviated by using * in the first place of the code when programming	351	
		352	
		361	
		362	
<b>Mode m = 5</b> (parameter 3125)			
<b>Events</b>	<b>Note</b>	<b>Parameter</b>	<b>Relay</b>
<b>External code entered from buttons</b>	Always valid	3211-3215	
	Valid for DAY	3311-3315	
	Valid for NOC	3411-3415	
	Always valid	3221-3225	
	Valid for DAY	3321-3325	
	Valid for NOC	3421-3425	
	Always valid	321*	
	Valid for DAY	331*	
	Valid for NOC	341*	
	Always valid	322*	
Valid for DAY	332*		
Valid for NOC	342*		
<b>Internal code entered on the phone</b>	1- or 2-digit code ca be used The default setting is a 2-digit code, which can be shortened by using * in the first position of the code when programming.	351	
		352	
		361	
		362	

Mode m = 4			
Events	Note	Parameter	Relay
Pressing a button	any button except the button set by 311* or 312*	3114	
		3124	
	button set by parameter 311* or 312*	3114	
		3124	
Mode m = 6			
Events	Note	Parameter	Relay
Pressing a button	any button except the button set by 311* or 312*	3116	-
		3126	-
	button set by parameter 311* or 312*	3116	
		3126	

Note: T1 – relay switching time 1 (*parameter 371*)  
T2 – Time between relay pulses 1 (*parameter 301*)  
T3 – Time between switching on relay 1 and relay 2 (*Parameter 39*)  
T4 – relay switching time 2 (*parameter 372*)  
T5 – Time between relay pulses 2 (*Parameter 302*)

**Tab. 1 Relay Control Table**

### 3.4 Incoming call

An incoming call is a call to the door communicator (initiated by a person inside the building). After dialing the number of the branch where the door communicator is connected, the door communicator line will ring and after the set number of rings (*parameter 51*), the door communicator will pick up and it is possible to talk. The options are similar to those for an outgoing call, with the following exceptions:

1. During the first 10 seconds, it is possible to enter the combination "**# and service password**" (*parameter 44*), the door communicator then enters the programming mode.
2. When the DIP1 switch ("SERVICE") is switched to the ON position, the door communicator goes straight into programming mode without entering the service password after picking up the line
3. An incoming call may be disabled from controlling the relay (*parameters 381 and 382*).

### 3.4.1 Door communicator with keyboard – VBDKey module

The keyboard module is detected automatically, but for proper operation, the following parameters must be set:

- Parameter 49 – Keyboard Mode.
  - If it is 0, the phone numbers are dialed from the keypad as on the phone. The caller simply enters the numerical combination and after exceeding the time given by the maximum time between keystrokes (*parameter 53*), the door communicator picks up and dials the entered phone number.
  - If it is 1, only the two-digit combination 01-99 is entered on the keyboard as the memory address where the phone number is stored. This number combination corresponds to the numbers of the direct dial buttons. That is, entering 01 on the keyboard dials the same number as pressing the 1 button. In both cases, the number that will be dialed also depends on the DAY/NIGHT setting.
- Parameter 40 – DTMF selection from the keyboard during a call.

Parameter value 40	Meaning of the symbol 
0	DTMF dialing is not allowed
1	DTMF*
2	DTMF #
3	DTMF A

**Key symbol**  = when pressed, the number combination is always understood as an External code used for relay control.

**X symbol**  = when pressed, the door communicator immediately hangs up or cancels the input of the External code.

## 4 Parameter programming

---

### 4.1 Programming with your phone

#### 4.1.1 Entry into programming

The Fores VarioBell is put into programming mode in two ways:

1. **using a password** – Incoming call only! – pick up the phone and dial the number where the door communicator is connected (*either the branch number if you are connected to the PBX, or the number of the state line to the building where the door communicator is located and be transferred to the branch where the door communicator is connected*). The door communicator picks up (you can hear the pick-up signal – see chapter 3.1 Pg. 27) up to 10 sec dial **#xxxx**, where xxxx is the service password for accessing programming (**by default, xxxx=0000**). If the password is correct, the door communicator switches to programming mode – a switch signal is heard and is immediately heard *Programming mode prompt* (see chapter 3.1 Pg.27).
2. **using DIP 1 "SERVICE"** – incoming call only! – you make the connection with the door communicator in the same way as in point 1, but if the DIP switch 1 is switched to the "ON" position, the door communicator goes straight to the programming mode after picking up – you hear the pick-up signal, the signaling of switching to the programming mode and then you can hear the *Programming mode prompt* (see chapter 3.1 Pg.27).

When you have finished programming, do not forget to return DIP 1 to the OFF position!

#### 4.1.2 Parameter programming

The default state for programming is announced *by Programming mode prompt*. The door communicator returns to this state every time (5 seconds) no matter what you start programming.

The programming mode distinguishes two kinds of parameters. One group are **parameters with a fixed length** – there are most of them. The parameter is always stored immediately after reaching the obligatory length and the programming is confirmed by the signal *Command or parameter accepted*. The second group are **parameters with variable length** (*parameter 1xx, 2xx, 32, 33, 34*), then the parameter is **confirmed** and written only after the idle time has elapsed (5 sec). The parameter is immediately entered when the maximum number of characters (numbers) to be written is fulfilled – for *parameters 1 and 2* (phone numbers) the maximum is 24, for *parameters 32, 33, 34* (external codes) the maximum length is 6.

If you enter a number (character) that is not inadmissible during programming, the door communicator immediately sends **an error signal** (*Command or parameter rejected*), the parameter is not written or changed, the door communicator returns to the state in which it expects parameters to be

entered and it is possible to repeat the parameter setting or program another parameter.

The door communicator remains in programming mode, if no DTMF tone is received for the time specified by parameter 52, then it will automatically hang up. With each DTMF tone received, the time until automatic hang up is set again to 2 minutes. You can exit the programming mode either by hanging up or by selecting *parameter 9*.

## 4.2 Programming from a PC – ForesSet

To set up the door communicator using a personal computer (PC), it is necessary to have a special USB-KAB cable and the ForesSet program, and the door communicator must also be connected to a telephone line.

### Procedure:

- Connect the door communicator to the line
  - Connect the door communicator and the PC with a USB cable. The door communicator picks up the line and within 3 seconds there is a tone to switch to programming mode (see chapter 3.1 Pg. 27).
  - Run the ForesSet program. During the operation (start-up) of the ForesSet program, the door communicator is in programming mode and until the USB cable is disconnected from the door communicator, it does not perform any other activity. If the connection is lost, it is necessary to disconnect the cable from the door communicator and reconnect it – the door communicator will pick it up.
1. Establishing a connection between the door communicator and the PC program is indicated by displaying the firmware version and the number of restarts at the bottom of the status bar.
  2. For easy orientation, the parameters in the ForesSet program are marked with the same codes as when programming from a phone. This makes it easier to orient yourself and also understand which parameter means what.
  3. For details on how to set up, see the program's help and the [www.alphatech.cz](http://www.alphatech.cz) manufacturer's website.
  4. USBKAB is a special cable with galvanic isolation and a level converter. Galvanic isolation is necessary because the telephone line must not be grounded and the PC is usually grounded.

## 5 Description of configuration parameters

Parameters always start with a fixed, mandatory part (parameter number) and end with a variable part – the parameter value. No special prefix or postfix characters are entered before or after the parameter. After the parameter is completely entered and written to memory, a confirmation will be heard, if the wrong value is entered, an error signal will be heard immediately.

### 5.1 Direct selection of numbers – memories

Parameter	Value	Meaning	Default
1	tt nn...	Phone number <b>nn</b> assigned to the <b>tt</b> button	-

**tt** – button number, always entered as two digits [01-99]

**nn** – phone number of up to 24 digits The assignment specified in the table is used to store additional selection flags.

After entering each digit, the next one must be entered in 5 seconds otherwise the phone number is considered finished and is written to memory.

The numbers stored in parameter 1 are the **numbers of the first group**, or the numbers of the **Day mode**.

Factory setting **8##** does not change or delete these numbers.

Meaning	Input
0–9	0–9
#	#
*	**
Pause	*0

Parameter	Value	Meaning	Default
2	tt nn...	Phone number <b>nn</b> assigned to the <b>tt</b> button	-

**tt** – button number, always entered as two digits [01-99]

**nn** – phone number of up to 24 digits The assignment specified in the table is used to store additional selection flags.

After entering each digit, the next one must be entered in 5 seconds otherwise the phone number is considered finished and is written to memory.

The numbers stored in parameter 2 are the **numbers of the second group**, or the numbers of the **Night mode**.

Factory setting **8##** does not change or delete these numbers.

Meaning	Input
0–9	0–9
#	#
*	**
Pause	*0

**Note 1:** the Day/Night mode settings remains set even after the line is disconnected

**Note 2:** there are max. 98 buttons available – tt=01-98

#### Examples of settings:

Button 1 (i.e. 01) is supposed to dial the number 358 during the day and '0 Pause 603441296' at night, then it is programmed for day **101358** and you wait 5sec for confirmation ♪, then for the night **2010\*0603441296** and you wait 5sec for confirmation ♪

Button 2 (i.e. 02) is supposed to dial 123#1\*23 day and night, then it is programmed for day **102123#1\*\*23** and you wait 5sec for confirmation ♪, then for night **202123#1\*\*23** and wait 5sec for confirmation ♪

**Note:** if you do not use the 2 groups of numbers mode, or Day/Night switching, it is recommended to set the Day-Night/TwoGroups mode (*parameter 47*), to *Day-Night* (see *parameter 45*) and then set the same code for Day/Night switching (*parameters 45 and 46*). This will guarantee that the door communicator will always be in Day mode and you only need to program phone numbers to Day mode (*parameter 1*).



## 5.2 Relays

Parameter	Value	Meaning	Default
31	r m	Relay r operates in m mode (1/2,1-6)	11 21

**r** – relay number [1-2]

**m** – Relay Mode [1-6 *For relay 1 i s mode m=5 is not available*]

Modes **m=1,4,5,6** are explained in detail in Tab. 1 Relay Modes on pg. 29

**m=1** Mode **Switch** – activates by command (internal code) or password (external code) 1 pulse for the time T1/T4 (used for electric locks) or 2 pulses when it switches on for the time T1/T4, opens for the time T2/T5 and switches on for the time T1/T4 (opening the mobile gate)

**m=2** switched on for the duration of line pick-up (**camera**) - by picking up the door communicator and switches off by hang-up

**m=3** switched on for the duration of line pick-up, and for T1/T4 after hanging up (**lighting**) - Switches on when the door communicator picks up and is closed for T1/T4 after hanging up the (during this time the line is occupied)

**m=4** Mode **button** – switched on for T1/T4 period when any button is pressed (used e.g. to connect an external doorbell or siren)

**m=5** Mode **gradual opening** – only relay 2 can be set to this mode, relay 1 is automatically set to mode m=1. By command (internal code) or password (external code), relay 1 is activated for the time t1, for the time t3 it waits before switching on relay 2, then relay 2 is activated for the time t4 and then the door communicator is hanged up. If the command or password entered corresponds to two pulses, then there will always be two pulses in the sequence, separated by time t2/t5. Explanation in Tab. 1 on pg. 29.

**Note.** *The command or password for relay 1 starts the whole sequence, if you use the command or password for relay 2, only relay 2 is controlled as in mode m=1.*

**m=6** It is switched on when the button set by parameter 31r\* is pressed. There can be only one button assigned to each relay. The relay is activated for the T1/T4 period. This mode serves as a replacement for the doorbell connected to the Fores Vario system.

Parameter	Value	Meaning	Default
31	r*tt	The tt button triggers the relay r to be switched on when it is in mode M=6 (01-99)	01

**r** – relay number [1-2]

**tt** – button number (memory), always entered as two digits [01-99]

This parameter is applied only if the relay **r** is in the m=6 mode. The value of **tt** determines which button triggers the relay **r** to be switched on for the time t1/t4.

Parameter	Value	Meaning	Default
32	rp hh...	in <b>DAY + NIGHT mode</b> , password hh... for relay r, in the order p=1-5, for 1 pulse and p=* for 2 pulses (00-999999)	-
33	rp hh...	in <b>DAY mode</b> password hh... for relay r, in the order p=1-5, for 1 pulse and p=* for 2 pulses (00-999999)	-
34	rp hh...	in <b>NOC mode</b> , the password hh... for relay r, in the order p=1-5, for 1 pulse and p=* for 2 pulses (00-999999)	-

- r – relay number [1-2]
- p – order=[1 to 5] Up to 5 passwords (external codes) are available to switch on the relay with one pulse
- p – order = \*, there is one password (external code) to switch on the relay with two pulses
- hh... – password (external code) to control the relay by buttons or keypad. The password can be up to 6 digits; the minimum is 2 digits. The characters \* and # are not allowed because they cannot be entered.

The DAY+NIGHT set (parameter 32) is always valid, the DAY set (parameter 33) is valid only when the door communicator is in DAY mode, analogously the NIGHT set (parameter 34) is valid only when it is in NIGHT mode. When the mode **Two groups of numbers**, is used (parameter 47) the door communicator behaves as if it were in DAY mode in terms of the operation of external codes. The relay must be set in m=1 or m=5 mode by parameter 31.

To choose a password, you need to follow a few rules:

- Choose the password so that during frequent use it is not possible to observe from the wear and tear of certain buttons what numbers it is composed of
- Be careful about the coincidence of the beginning of the digits of the password, when one password starts the same as the other, e.g. the password for relay 1 is 1234 and for relay 2 is 12345, then always after pressing button 4, relay 1 is equipped, and relay 2 cannot be controlled.

**Note 1:** Switching to Day/Night mode remains set even after the line is disconnected

**Note 2:** In Fores door communicator sets, the number 0 in the external codes is represented by button 10.

Parameter	Value	Meaning	Default
<b>35</b>	<b>r aa</b>	<b>aa</b> command from the phone to turn on relay <b>r</b> 1 pulse (00-99,*0-*9)	155 266

**r** – relay number [1-2]

**aa** – Command (internal code) from the phone to turn on the relay [2 places]<sup>1</sup>  
The same command (internal code) can be set for both relays, then both relays are activated at the same time. It is useful to set the same command for switching on the relay and for hanging the door communicator (see *parameter 43*)

1) - The command is always programmed as two digits, but if you want to control the relay from the phone keypad with a single **digit**, enter **\*a** where **a** is the digit that causes the relay to be switched on.

For example: Relay 1 - switching with internal code 48 – programming: **35148** 🎵  
Relay 2 - switching with internal code 8 – programming: **352\*8** 🎵

Parameter	Value	Meaning	Default
<b>36</b>	<b>r cc</b>	<b>aa</b> command from the phone to switch on relay <b>r</b> 2 pulses (00-99,*0-*9)	150 260

**r** – relay number [1-2]

**cc** – Command (internal code) from the phone to turn on the relay [2 places]<sup>1</sup>  
The same command can be used for both relays, then both relays are activated at the same time.

1) - The command is always set as two digits, but if you want to control the relay with a single digit, enter **\*a** where **a** is the digit that should switch the relay to on. Switching on the relay with 2 impulses can be used, for example, at a mobile gate, which thus replaces the gate for the entry of people.

Example: We want to control the switching of relay 2 with one pulse, e.g. with the digit **8**, the hang-up also with the digit **8** and the switching on relay 2 with two pulses, e.g. with the digit **9**:

Programming: **352\*8** 🎵 , **432\*8** 🎵 , **362\*9** 🎵 .

When talking to the door communicator, you execute the command to open the gate (2 pulses) **9**, the first impulse sets the gate in motion, the second impulse stops the gate, the size of the gate opening for people to enter is given by the time between impulses (*parameter 30*). After people enter, dial **8**, then the door communicator makes one impulse and hangs up, the gate closes.

Parameter	Value	Meaning	Default
<b>37</b>	<b>r ss</b>	<b>ss</b> time [sec] relay <b>r</b> switching on for T1/T4 time (01-99)	105 205

**r** – relay number [1-2]

**ss** – Time T1 for which relay 1 is switched on, time T4 for which relay 2 is switched on [2 places 01-99]

Parameter	Value	Meaning	Default
<b>38</b>	<b>r p</b>	r relay control p for incoming call (0/1)	11 21

**r** – relay number [1-2]

**p** – parameter whether it is enabled **p=1** or disabled **p=0** control the relay when an incoming call occurs.

It makes sense to disable control when an incoming call is used, e.g. relay 2 in mode 1 controls the opening of the garage door, when the electronics open the door and it closes when the vehicle passes. Then the control from the phone could cause the door to open unintentionally permanently (it does not close – the vehicle has not passed).

Parameter	Value	Meaning	Default
<b>39</b>	<b>xx</b>	Time <b>xx</b> [sec] between switching on relays 1 and 2 in mode m=5 - time t3 (01-99)	10

**xx** – T3 time from switching off relay 1 to switching on relay 2 in mode **m=5** (gradual opening) [2 digits 01-99]

Parameter	Value	Meaning	Default
<b>30</b>	<b>r zz</b>	Time <b>zz</b> [sec] between pulses when relay <b>r</b> is switched on with two pulses - time T2/T5 (01-99)	105 205

**r** – relay number [1-2]

**zz** – T2 time between the first and second impulse for switching on relay 1  
T5 time between the first and second impulse for switching on relay 2 [2 places 01-99]

Parameter	Value	Meaning	Default
<b>3*</b>	<b>r e</b>	Exit button for relay r (0/1/2)	10 20

**r** – relay number [1-2]

**e** – exit button mode: **e=0** -off **e=1** - switched on for 1 pulse, **e=2** - Switched on for 2 pulses

### 5.3 Basic parameters

Parameter 41 for switching between tone (DTMF)/pulse dialing is ignored. Only tone dialing is supported.

Parameter	Value	Meaning	Default
42	z	Call prolongation character (* / #)	*

**z** – Call prolongation character \* or # (About 15 seconds before the end of the call, the communicator sends a notification (see p. 27), then the call can be prolonged)

Parameter	Value	Meaning	Default
43	g bb	Command to hang up the door communicator from the phone (00-99,*0-*9)	155 266

**g** – command order [1-2] (two commands are available so that the door communicator can be hang up when using any relay)

**bb** – command to hang the door communicator from the phone [2 digits]<sup>1</sup>

It is recommended to set the same command for switching on the relay (parameter 35.36) and the command for hanging up.

<sup>1</sup>) - The command is always programmed as two digits, but if you want to control the relay from the phone keypad with a single digit, enter \***a** where **a** is the digit that causes the relay to be switched on. (Example for parameter 35.36)

Parameter	Value	Meaning	Default
44	xxxx	Service Password (0000-9999)	0000

**xxxx** – Service password to enter programming mode



If you forget your password, then the following procedure is recommended:

- Open the door communicator cover
- Switch DIP1 to the ON position
- Call the door communicator
- After picking up the line, the door communicator is in programming mode. In this mode, the password can be changed 44xxxx
- return DIP1 to the OFF position
- Close the door communicator cover

Parameter	Value	Meaning	Default
45	dd	Command to switch to <b>DAY</b> (00-99,*0-*9)	11
46	nn	Command to switch to <b>NIGHT</b> (00-99,*0-*9)	11

**dd** – Command to switch to mode **DAY** [2 digits]<sup>1</sup>

**nn** – Command to switch to mode **NIGHT** [2 digits]<sup>1</sup>

*1) - The command is always programmed as two digits, but if you want to control the relay from the phone keypad with a single digit, enter \*a where a is the digit that causes the relay to be switched on. (Example for parameter 35.36)*

**Note 1:** The DAY/NIGHT mode status remains set even after the line is disconnected

**Note.. 2:** In the default settings, both commands are set the same to prevent accidental switching to NIGHT mode.

**! ATTENTION !!** If the door communicator is in a different mode (e.g. NIGHT) than the one for which you are setting the phone numbers (DAY, i.e. 1xx), it will dial the numbers of the mode in which it is switched (NGHT, i.e. 2xx) when you press a button! Therefore, it may dial different numbers than you expect or even signal an empty memory!

Parameter	Value	Meaning	Default
47	e	Day-Night/TwoGroups Mode (0/1)	1

**e** – Number selection mode **e=0** door communicator dials numbers from 1<sup>st</sup> and 2<sup>nd</sup> group sequentially, **e=1** door communicator dials numbers according to the door communicator mode **Day/Night** (parameters 45/46)

**! ATTENTION !!** In combination with parameters 45, 46, it may happen that the door communicator behaves unexpectedly – see the explanation above.

Parameter	Value	Meaning	Default
49	o	Keyboard Mode (0/1)	0

- o – **o=0** dialing the number as on a normal phone (the full number of the called person must be dialed on the keypad)
- o=1** only the 2-digit number of the memory under which the number of the called person is stored is entered on the keypad (the memory number matches the number of the button and respects the Day/Night switching – valid numbers are 01–99)

**!** **ATTENTION!!** Setting this parameter will significantly affect the function of the keyboard

Parameter	Value	Meaning	Default
40	d	DTMF selection from the keypad during a call (0-3)	0

- d – **d=0** During a call **it is impossible** dial DTMF from the keyboard
- d=1 can be** from the keyboard to dial DTMF, the key dials \*
- d=2 can be** from the keyboard to dial DTMF, the key dials #
- d=3 can be** from the keyboard to dial DTMF, the key dials **DTMF A**

Parameter	Value	Meaning	Default
4*	k	Hanging the line by pressing the same button again (0/1)	1

- k – hang up by pressing the same button:
  - k=0** pressing the button again causes the number to be dialed again
  - k=1** pressing the button again causes hang up

**!** **ATTENTION !!** Setting this parameter will significantly affect the dialing of numbers

## 5.4 Time parameters

Parameter	Value	Meaning	Default
51	q	Number of rings before the door communicator picks up an incoming call (1-9)	2

q – Number of rings q before the door communicator picks up an incoming call. The number can be set from 1 to 9.

Parameter	Value	Meaning	Default
52	d	Maximum call duration (0-9,*,#)	2

d – The maximum amount of time a call can last. The call can be extended during the call by dialing a character from the phone (\* or # - *Parameter 42*). The time is entered according to the table.

Time [min]	Input
0,5	0
1–9	1–9
15	*
30	#

Parameter	Value	Meaning	Default
53	w	Time between button presses (1-9)	2

w – Maximum time [sec] between button presses [range 1-9]

- **external code** – if the time between pressing two consecutive buttons is greater than the time w, the code will not be evaluated correctly
- **number selection** – if the button pressed is same as the first digit of the external code, then dialing is delayed by the time w, because it is not known yet whether it is a part of the code or a phone memory number

Parameter	Value	Meaning	Default
54	z	Hangup time during redial (1-5)	2

z – The time [sec] for which the door communicator hangs up before picking up again to repeat the dial (used when line is busy or button was pressed during a call) [range 1-5]

Parameter	Value	Meaning	Default
55	r	Delay before the dialing starts (1-5)	1

r – the time [sec] after picking up before the door communicator starts dialing phone number [range 1-5].

This time is different for each phone system / PBX, but as a rule, most phone systems / PBXs can process the dial within 2 seconds after picking up the line.

Parameter	Value	Meaning	Default
<b>56</b>	<b>hh</b>	No. of ringtones before hang-up (04-99)	12

**hh** – number of rings heard from line after the end of the dial before door communicator hangs up because no one picked up. [range 04-99]. The dial is repeated if the two group dial mode (parameter 47) is set.

Parameter	Value	Meaning	Default
<b>500</b>	<b>x</b>	Tone detector mid frequency (1-0)	3 (375-475Hz)
<b>501</b>	<b>y</b>	Number of busy tones to hang up (2-0)	4
<b>502</b>	<b>z</b>	Continuous tone duration (1-5)	3 (3s)

**x** – medium frequency of the tone detector – set in the case of non-standard signaling the phone system / PBX – see table

frequency [Hz]	x – choice
275-375	1
325-425	2
375-475	3
425-525	4
475-575	5
525-625	6
575-675	7
625-725	8
675-775	9
725-825	0

**y** – minimum number of busy tones required for detection [2-0], where 0 means 10 busy tones

**z** – minimum duration of continuous tone (for detection of dial tone on PBX) [1-5 sec]

Parameter	Value	Meaning	Default
<b>503</b>	<b>tt</b>	DTMF tone duration (04..16)	10 (100ms)
<b>504</b>	<b>mm</b>	DTMF space duration (04-16)	10 (100ms)
<b>506</b>	<b>p</b>	Pause duration (1-0)	4 (800ms)

**tt** – The duration of the DTMF tone is determined by the formula:  
**(number entered) x 10 = tone duration** [ms] - [04-16 i.e. 40-160ms]

**mm** – The duration of the space between the DTMF tones is determined by the formula:  
**(number entered) x 10 = space duration** [ms] - [04-16 i.e. 40-160ms]

**p** – The duration of the pause is determined according to the formula:

***Entered number x 100 + 400 = pause duration [ms]***  
[range 1-0 i.e. 500-1400ms]

## 5.5 System parameters

Parameter	Value	Meaning	Default
<b>61</b>	<b>z</b>	Acoustic signaling (acknowledgment, error, empty memory, end of call...) (0/1)	1

By default, the status of the door communicator is signaled acoustically.

z=0 – signaling is off

z=1 – the signaling is on

Parameter	Value	Meaning	Default
<b>62</b>	<b>v</b>	Acoustic signaling pick up/hang up (0/1/2)	1

By default, the pick-up and hang-up of the line is acoustically signaled, but this may cause false dialing or a change in the operating mode for some types of phone system / PBX.

v=0 – pick-up and hang-up signaling off

v=1 – pick-up and hang-up signaling on (Type1)

v=2 – pick-up and hang-up signaling on (Type2)

See chapter 3.1, pg. 27.

Parameter	Value	Meaning	Default
<b>63</b>	<b>u</b>	Acoustic signaling of ticking into a call (0/1)	0

By default, ticking into a call is turned off. By turning on this signaling, it is possible to distinguish a call from the door communicator by a regular ticking in the call.

u=0 – Ticking into the call is off

u=1 – Ticking into a call is on

Parameter	Value	Meaning	Default
<b>65</b>	<b>z</b>	Acoustic signaling of relay switching (0/1)	0

By default, the relay switching signal is switched off **z=0**. Some locks do not "buzz" when the door is opened, and it is then not obvious to the person who comes that they can already open the door.

When **z=1** is switched on, a sound simulating the sound of the lock is heard from the door communicator speaker for the duration of the relay switching.

*Note 1: This function is only available for relay modes **m=1**, **m=5***

*Note 2: Even when the relay is switched on by two pulses, the acoustic signaling is switched on only when the relay is switched on, not in the gap between as in the previous generation of door communicators.*

Parameter	Value	Meaning	Default
67	b	BabyCall – call without the need to program a phone number (0/1)	0

By default, **b=0** is off. Turning on the **b=1** disables the acoustic signaling of an empty memory and after pressing the button with empty memory, only a beep (confirmation) is heard and the call is made as if a number had been dialed.

**Attention:** The tone detector is not active for the first 10 seconds of the call (waiting for the phone system / PBX to react and dial the number by the phone system / PBX).

Parameter	Value	Meaning	Default
68	m	Silence of the line when the lock is closed (0/1)	0

By default, **m=0** is off. Activating the **m=1 function** silences the acoustic path when the relay (1 or 2) is switched on in the "electric lock" mode (modes 1 and 5). This function is there because if the code lock function is used, the tone of the exchange can be heard for the duration of the lock. For some customers, this can be distracting.

Parameter	Value	Meaning	Default
6#	s	Set the number of buttons (0/1/2)	2

This constant is used for modular assemblies to determine the position of button No. 1. The number has to reflect number of buttons visible on the module front panel. In this case is the button number 1 the first one.

number of buttons on module	s - choice
0	0
1	1
2	2

 **ATTENTION !!** Setting this parameter will significantly affect the dialing of numbers.

Parameter	Value	Meaning	Default
6*	t	Delayed start for PBX with line test (Siemens..) (0/1)	0

By default, **t=0** is off. By turning on **t=1**, the door communicator immediately goes to sleep after connecting the line and only after 5 sec the initialization will the door communicator complete the initialization. This will delay the pick-up of the line after the voltage is connected – the moment when the phone system / PBX is restarting or switched on.

## 5.6 HandsFree Setup

The speaker volume and microphone sensitivity are adjusted using potentiometers – see chapter 1.3, pg. 10.

## 5.7 Basic settings and deletion

Parameter	Value	Meaning	Default
8#	#	Set door communicator to default settings	only 3..-6..

These settings do not affect the parameters of groups **1** and **2** (stored phone numbers) it works as the execution of commands 83-86 at the same time.

Parameter	Value	Meaning	Default
81		Delete all numbers in Group 1((Day mode)	-
82		Delete all numbers in Group 2 (Night mode)	-
83		Set default settings for 3x parameters only	only 3..
84		Set default settings for 3x parameters only	only 4..
85		Set default settings for 3x parameters only	only 5..
86		Set default settings for 3x parameters only	only 6..

Parameters 81 and 82 will delete all phone numbers.

Parameters 83 – 86 will perform selective default settings only for parameters starting with 3, 4, 5, 6. The default values of the settings are listed for each parameter on the right – in the "Default" column.



**CAUTION !!** Deletion or setting to default is irreversible. Then the door communicator must be re-programmed as needed.

## 5.8 End of programming

Parameter	Value	Meaning	Default
9		Exit programming mode	-

The door communicator immediately hangs up

## 5.9 Overview of parameters

Parameter	Value	Meaning	Default
1	tt nn...	Phone number <b>nn</b> assigned to the <b>tt</b> button	-
2	tt nn...	Phone number <b>nn</b> assigned to the <b>tt</b> button	-
31	r m	Relay <b>r</b> operates in <b>m</b> mode (1-6)	11 21
31	r*tt	The <b>tt</b> button triggers the relay <b>r</b> to be switched on when it is in mode M=6 (01-99)	01
32	rp hh...	in <b>DAY + NIGHT mode</b> , password <b>hh...</b> for relay <b>r</b> , in the order <b>p</b> =1-5, for 1 pulse and <b>p</b> =* for 2 pulses (00-999999)	-
33	rp hh...	in <b>DAY mode</b> password <b>hh...</b> for relay <b>r</b> , in the order <b>p</b> =1-5, for 1 pulse and <b>p</b> =* for 2 pulses (00-999999)	-
34	rp hh...	in <b>NOC mode</b> , the password <b>hh...</b> for relay <b>r</b> , in the order <b>p</b> =1-5, for 1 pulse and <b>p</b> =* for 2 pulses (00-999999)	-
35	r aa	<b>aa</b> command from the phone to turn on relay <b>r</b> 1 pulse (00-99,*0-*9)	155 266
36	r aa	<b>aa</b> command from the phone to turn on relay <b>r</b> 2 pulses (00-99,*0-*9)	150 260
37	r ss	<b>ss</b> time [sec] relay <b>r</b> switching on for T1/T4 time (01-99)	105 205
38	r p	<b>r</b> relay control <b>p</b> for incoming call (0/1)	11 21
39	xx	Time <b>xx</b> [sec] between switching on relays 1 and 2 in mode m=5 - time t3 (01-99)	10
30	r zz	Time <b>zz</b> [sec] between pulses when relay <b>r</b> is switched on with two pulses - time T2/T5 (01-99)	105 205
3*	r e	Exit button for relay <b>r</b> (0/1/2)	10 20
42	z	Call prolongation character (* / #)	*
43	g bb	Command to hang up the door communicator from the phone (00-99,*0-*9)	155 266
44	xxxx	Service Password (0000-9999)	0000
45	dd	Command to switch to <b>DAY</b> (00-99,*0-*9)	11
46	nn	Command to switch to <b>NIGHT</b> (00-99,*0-*9)	11 <sup>1</sup>
47	e	Day-Night/Two groups mode (0/1)	1

<sup>1</sup>: By default, parameters 45 and 46 are set to the same value to prevent accidental switching to NIGHT mode. If you will use DAY/NIGHT switching set 10 for parameter 46.

<b>49</b>	<b>o</b>	Keyboard Mode (0/1)	0
<b>40</b>	<b>d</b>	DTMF selection from the keypad during a call (0-3)	0
<b>4*</b>	<b>k</b>	Hanging the line by pressing the same button again (0/1)	1
<b>51</b>	<b>q</b>	Number of rings before the door communicator picks up an incoming call (1-9)	2
<b>52</b>	<b>d</b>	Maximum call duration (0-9,*,#)	2
<b>53</b>	<b>w</b>	Time between button presses (1-9)	2
<b>54</b>	<b>z</b>	Hang-up time during redial (1-5)	2
<b>55</b>	<b>z</b>	Delay before the dialing starts (1-5)	1
<b>56</b>	<b>hh</b>	No. of ringtones before hang-up (04-99)	12
<b>500</b>	<b>x</b>	Tone detector mid frequency (1-0)	3 (375-475Hz)
<b>501</b>	<b>y</b>	Number of busy tones to hang up (2-0)	4
<b>502</b>	<b>z</b>	Continuous tone duration (1-5)	3 (3s)
<b>503</b>	<b>tt</b>	DTMF tone duration (04..16)	10 (100ms)
<b>504</b>	<b>mm</b>	DTMF space duration (04-16)	10 (100ms)
<b>506</b>	<b>p</b>	Pause duration (1-0)	4 (800ms)
<b>61</b>	<b>z</b>	Acoustic signaling (acknowledgment, error, empty memory, end of call...) (0/1)	1
<b>62</b>	<b>v</b>	Acoustic signaling pick up/hang up (0/1/2)	1
<b>63</b>	<b>u</b>	Acoustic signaling of ticking into a call (0/1)	0
<b>65</b>	<b>z</b>	Acoustic signaling of relay switching (0/1)	0
<b>67</b>	<b>b</b>	BabyCall – call without the need to program a phone number (0/1)	0
<b>68</b>	<b>m</b>	Silence of the line when the lock is closed (0/1)	0
<b>6#</b>	<b>s</b>	Set the number of buttons (0/1/2)	2
<b>6*</b>	<b>t</b>	Delayed start for PBX with line test (Siemens..) (0/1)	0
<b>8#</b>	<b>#</b>	Set door communicator to default settings	Only 3..6..
<b>81</b>		Delete all numbers in Group 1((Day mode)	-
<b>82</b>		Delete all numbers in Group 2 (Night mode)	-
<b>83</b>		Set default settings for 3x parameters only	only 3.

<b>84</b>		Set default settings for 3x parameters only	only 4.
<b>85</b>		Set default settings for 3x parameters only	only 5.
<b>86</b>		Set default settings for 3x parameters only	only 6.
<b>9</b>		Exit programming mode	-

## 6 Technical parameters

### 6.1 Electrical Parameters

Parameter	Value	Terms and Conditions
Minimum line current	25 mA	Pick up
Minimum line voltage	18 V	Hang up
Voltage on the line when picked up	<12 V	I = 25 mA
Bandwidth	300 Hz – 3400 Hz	20–60 mA
Ringtone impedance	min. 10–25 V	
Ringer detector sensitivity	12 V DC (11-24 V), 12 V AC (10-18 V )	
Power supply for lighting, switches and heaters	250 mA	12 V <sub>ss</sub>
Max lighting and heating consumption	48 V	při I <1 A
Max. relay contact voltage	1,5 A	při U <30 V
Max. relay contact current	- 20 až + 60 °C	
Operating temperature	IP44	
Coverage	By design and assembly	

### 6.2 Mechanical dimensions

Item Type	Dimensions HxWxD [mm]			
	1 module	2 modules	3 modules	2 x 3 modules
Module	100 x 100			
Mounting box	136x99x56	244x99x56	328x99x56	-
Edge frame	173x128	256x128	358x128	-
Cover frame	178x130	281x130	383x130	383x230
Rainhood	165x142x45	268x142x45	370x142x45	370x242x45
KPD with rainhood	165x142x80	268x142x80	370x142x80	370x242x80



Alphatech s.r.o. declares under its own sole responsibility that product is in an agreement with common requirements and other related EU regulations. The original of the statement can be found at [www.alphatech.cz](http://www.alphatech.cz) in section *Support*.



Do not contaminate the environment, make sure that the packing material will be disposed in accordance with applicable laws and regulations. At the end of the service life, It is necessary to ensure the environment-friendly disposal, it is recommended to recycle separate parts. The components to be recycled are marked with a symbol of recycling and symbol of a specific material.



**Alphatech spol. s r. o.**  
**Jeremenkova 88**  
140 00 Prague 4, Czech Republic  
**tel. 244 461 072**

E-mail: [info@alphatech.cz](mailto:info@alphatech.cz)  
Internet: <https://www.alphatech.cz>  
our GPS coordinates (WGS 84)  
N 50°02'35.5" E 14°25'42.0"

31.3.2026