

ForesLift Compact



User Manual v 1.1

Compatibility of ForesLift Compact with Brave Link Lift Watch (BLLW)

The ForesLift Compact (FLC) is an emergency call communicator operating according to the latest version of the EN81-28 standard. It is the direct successor to the BLLW model.

- Same dimensions and design
- Same add-on modules – LCL-SPK
- The same USB cable USBKAB or DTMF can be used for programming
- The new LiftConfigurator software also supports BLLW
- Same configuration file
- Tone dialing only
- Simple adjustment of the volume and sensitivity of the microphone using classic potentiometers
- Up to 5 FLC communicators in parallel
- signaling according to EN81-28:2022
- Blocked emergency call input from the on/off switch cabin or separated by an optocoupler
- Emergency call blocking input for switch/disconnect contact or separated by optocoupler
- Unblocked multi-purpose input (emergency call, technician arrival...) for NO/NC contact
- 1 input for connecting LCL SPK above or below the cab
- External LEDs connectable via optocouplers
- Integrated microphone and speaker
- Possibility to connect an external microphone and speaker (induction loop)



The manufacturer continuously improves the software. The FLC communicator is equipped with the ability to load a new firmware version at any time using a regular computer. You can get the latest firmware version at www.alphatech.cz.



Version V1.1 Manual 14.03.2026

(for FW 1.80 and higher)

Alphatech spol. s r. o.

Jeremenkova 88

140 00 Prague 4-CZ

tel: (+420) 244 461 072

www.alphatech.cz / info@alphatech.cz

Contents

1. BASIC DESCRIPTION	5
1.1 FEATURES.....	5
1.2 PROGRAMMING USING DTMF	6
1.2.1 <i>Communication via GSM network</i>	6
1.2.2 <i>Communication via IP network</i>	6
1.2.3 <i>Connecting the communicator to the PBX with the system phone</i>	6
1.3 DESCRIPTION OF THE FLL COMMUNICATOR	6
1.4 CONNECT A COMMUNICATOR.....	12
1.4.1 <i>Connecting a telephone line</i>	12
1.4.2 <i>Connecting the SHAFT ALARM button</i>	13
1.4.3 <i>Connecting the ALARM CABINE emergency call button</i>	15
1.4.4 <i>Connecting the indicator LEDs</i>	16
1.4.5 <i>Connecting the emergency call blocker ALARM FILTER</i>	17
1.4.6 <i>Connection below/above the cab</i>	18
1.5 CONNECTING SWITCHBOARD	19
1.5.1 <i>Wiring SwitchBoard</i>	19
1.5.2 <i>SwitchBoard features</i>	20
1.5.3 <i>Programming SwitchBoard</i>	21
1.5.4 <i>Technical parameters of SwitchBoard</i>	22
1.6 INSTALLATION	23
2. OPERATION OF THE FORESLIFT LINE COMMUNICATOR	25
2.1 SIGNALING OVERVIEW	25
2.2 CALLING FROM THE COMMUNICATOR	26
2.2.1 <i>Emergency call</i>	26
2.2.2 <i>Emergency call with blocking</i>	28
2.2.3 <i>Service call (based on timer)</i>	29
2.2.4 <i>Technical calls</i>	29
2.2.5 <i>Error call</i>	30
2.2.6 <i>Call Confirmation</i>	30
2.2.7 <i>Confirm a call with a code</i>	31
2.2.8 <i>Connection to the machine room</i>	33
2.2.9 <i>Incoming calls</i>	34
2.2.10 <i>Parallel connection of FLL communicators</i>	35
2.2.11 <i>Call Center and Call Types</i>	37
3. PARAMETER PROGRAMMING	38
3.1 PROGRAMMING WITH YOUR PHONE.....	38
3.1.1 <i>Entering programming mode</i>	38
3.1.2 <i>Parameter programming</i>	38
3.2 PROGRAMMING FROM A PC – LIFTCONFIGURATOR	39
3.2.1 <i>Programming SwitchBoard</i>	41
3.3 INSTALLING LIFTCONFIGURATOR.....	42
4. PARAMETER DESCRIPTION	43

4.1 PHONE NUMBERS	43
4.2 ELEVATOR OPERATION	46
4.3 BASIC PARAMETERS.....	49
4.4 TIME PARAMETERS	54
4.5 SYSTEM PARAMETERS.....	59
4.6 HANDSFREE SETUP.....	62
4.7 BIT PARAMETERS AND POWER SUPPLY.....	63
4.8 PRESETTING BASIC VALUES, DELETING.....	67
4.9 END OF PROGRAMMING.....	68
4.10 OVERVIEW OF PARAMETERS	69
5. SHORTENED PROCEDURE FOR PROGRAMMING THE COMMUNICATOR	72
6. TECHNICAL PARAMETERS.....	73
6.1 ELECTRICAL PARAMETERS	73
6.2 MECHANICAL PARAMETERS.....	73

1. Basic description

1.1 Features

- The FLC communicator is powered only from the telephone line.
- Integrated microphone and speaker, instead it is possible to connect an external microphone and speaker, or an induction loop
- Programming by DTMF from a phone or from a PC via a USB cable.
- The call status indication is according to the valid version EN81-28:2022 using yellow and green LEDs. There are two sets in the unit for the alternative position of the LEDs. In addition, optron-separated outputs can be used for LEDs powered by an external source.
- Buttons can be used of both types (NO) or (NC)
- Two buttons can be connected. The SHAFT input has no blocking and allows more functions, CABIN is the button used for emergency call from the elevator cabin
- Emergency Call Blocking Input BLK
- Optional timer call blocking (derived e.g. from a door switch)
- The CABIN and BLK inputs are available as a contact connection option or separated by an optron.
- The time for activating each button is individually adjustable from 0.5 sec to 30 sec
- A SwitchBoard is recommended for connection to the machine room, and allows you to connect up to 5 communicators in parallel
- Automatic check of system functionality – Service call (automatic call to a preset number in the time period of 1 to 59 days)
- Option to turn on acoustic ticking in a call for call recognition
- Adjustable parameters of tone dial, Pause length. Pulse dialing is not supported
- Adjustable parameters of the tone detector and acoustic signaling
- Up to 6 numbers for emergency calls, another 3 numbers for service, technical and error calls all with automatic or manual call confirmation. Max 16 digits – including *, #, Pause characters.
- Memory for the last two dialed numbers
- Error calls – stuck buttons CABIN, SHAFT; fault in the acoustic path (microphone/speaker)
- Technical calls – arrival/departure of the elevator technician; Alarm state exit;
- Possibility to call the machine room (SHAFT button function)
- Ability to mute during service, technical and error calls

1.2 Programming using DTMF

1.2.1 Communication via GSM network



If you do not program the communicator on an analogue telephone network (e.g. from a mobile phone, mobile/GSM gateway, VoIP...) it may happen that it cannot be programmed or the programming is unreliable. This is because of the way DTMF is transmitted over the network – whether inband or outband. Inband transmission conversions to digital from and back often reduce the quality so much, that some digits (most often 6,3) or all of them are distorted so that they are not recognized. Unfortunately, the method of transmission in the mobile network (and between them!) cannot be influenced in any way and the method of DTMF transmission depends purely on the operator. In this case, connect an analogue phone to the communicator in parallel, call the communicator and after it picks up, pick up the parallel phone and program the communicator from it. However, this is only applicable when programming directly on site.

Preferable to direct programming via DTMF is the use of SMS messages to create DTMF directly using the Alphatech GSM gateway. However, the Alphatech GSM gateway must be equipped with this function. This method allows you to set up the communicator reliably even remotely.

1.2.2 Communication via IP network



VoIP telephony devices (IP phone, IP gate...) have a configurable DTMF transmission mode (SIPinfo, RFC2833 and DTMF inband). If DTMF is not transmitted, make sure that the same mode is set on the network or that automatic switching between modes is not disabled. On the end device to which the communicator is connected, then check the DTMF settings.

DTMF inband is a voice channel transmission that can suffer from similar problems as GSM transmission.

1.2.3 Connecting the communicator to the PBX with the system phone

As a rule, the system phone cannot automatically send DTMF when the keypad button is pressed. It is necessary to set the option in the PBX to enable DTMF on one of the function keys of the system phone.

1.3 Description of the FLC communicator

Figures 1 and 2 show all the connection and functional parts. The description of the functions follows.

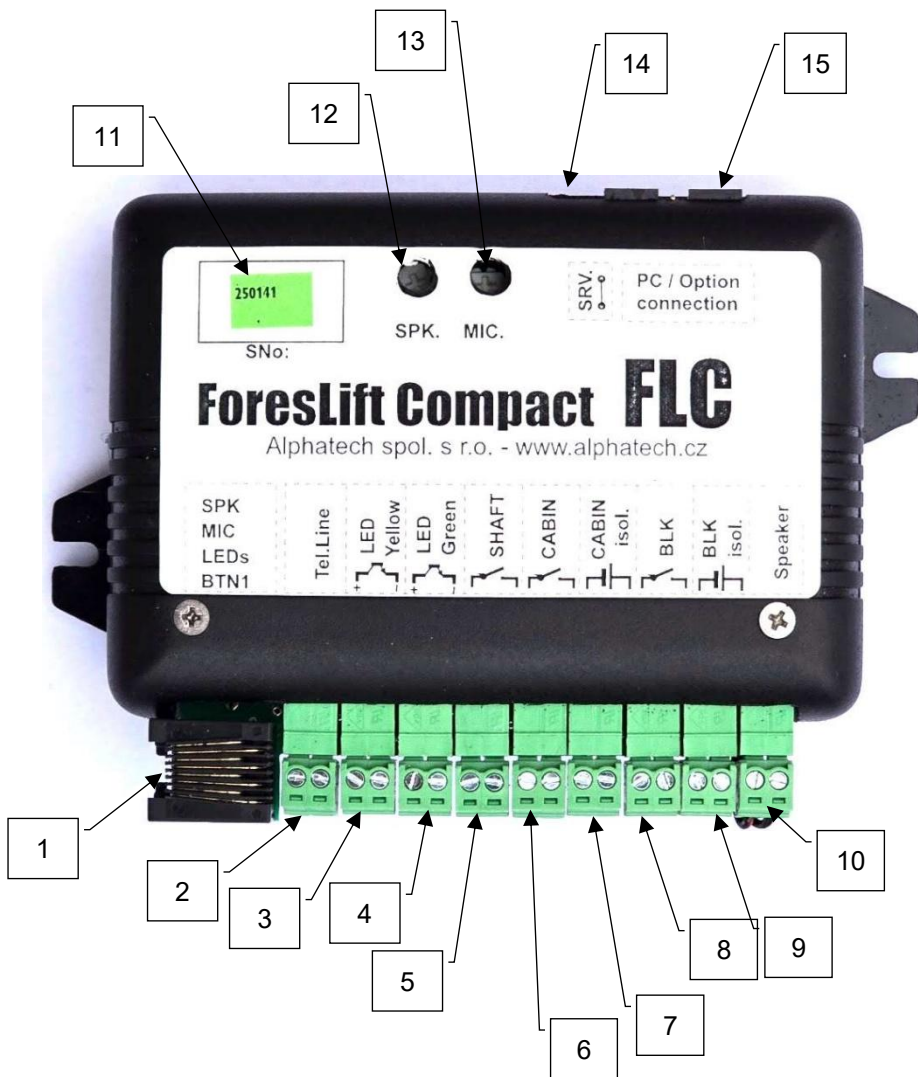

Fig. 1: FLC communicator – rear view



Fig. 2: FLL communicator – front view

The communicator is equipped with a microphone and speaker as standard. The speaker connection is solved in such a way that an external speaker, induction loop or FloorTalker floor detector can be easily connected. In addition, the communicator is equipped with one RJ45 connector for remote connection of LCL SPK modules below or above the cabin. This connection includes signals for the microphone, speaker, both

LEDs, and the SHAFT ALARM button. Pay attention to the polarity of the microphone connected, you have to keep it (+ -)!

1. **RJ45 connector for remote connection** below / above the cabin. The connection includes signals for speaker (50Ω), microphone (electret), green and yellow LEDs and the SHAFT ALARM button
2. **Tel.Line** – connector for connecting a telephone line, i.e. an analogue telephone line, a PBX, a state line, an analogue GSM or VoIP gateway output.
3. **LED Yellow** connector – optron output for controlling the green LED. **The connection requires a suitable current limiting resistor and power from an external source.**
4. **LED Green** connector – optron output for controlling the green LED. **The connection requires a suitable current limiting resistor and power from an external source.**
5. **SHAFT** – the input of the button intended for elevator service (not placed on the cabin panel). It allows emergency calls, even in the event of blockage (the **BLK** input does not affect calls from this button), it is also possible to make a technical call *End of Emergency* ("the technician is on site") or call the engine room.
6. **CABIN** – the input of the emergency call button from the elevator cabin. This input is activated by either closing or opening a contact (nothing else must be connected to this contact!).
7. **CABIN isol.** – Emergency call button input from the elevator car. This input is equipped with an optocoupler and allows connection to a button that directly controls the siren (12 V). This input is activated by applying or disconnecting voltage (5V-24V).
8. **BLK** – emergency call blocking input. Calls can be blocked when the CABIN button is pressed. The blocking can be derived from a fault condition from the elevator switchboard, or the automatic locking function derived from the door movement (door switch) can be activated. This input is activated by either closing or opening a contact. (nothing else must be connected to this contact!).
9. **BLK isol.** – emergency call blocking input with optocoupler. Calls can be blocked when the CABIN button is pressed. The blocking can be derived from a fault condition from the elevator switchboard, or the automatic locking function derived from the door movement (door switch) can be activated. This input with an optocoupler is activated by either applying or disconnecting a voltage of 5 V – 24 V.
10. **Speaker** connector for connecting an internal/external speaker
11. **SNo:** – each communicator is equipped with a unique serial number for identification. This number is sent by the communicator in response to a request for identification with a parameter confirmation code **47** – see p. 50.
12. **SPK** - potentiometer used to adjust the speaker volume.

13. **MIC** - potentiometer used to adjust the sensitivity of the microphone.
14. Jumper **SRV** - when connecting the jumper, you can enter the programming mode from your phone without entering a password. It is only used if you forget your password. After logging in, you can change your password.
15. **PC** – connector for connecting a USBKAB cable. This cable ensures a galvanically isolated connection of the communicator with the USB interface of the computer. Drivers for the cable are on the website www.alphatech.cz. Used for service purposes – uploading configuration, voice messages or new firmware. The communicator has to be powered by a telephone line during configuration etc.
16. **Internal Speaker** 50Ω
17. **Internal microphone**

1.4 Connect a communicator

1.4.1 Connecting a telephone line

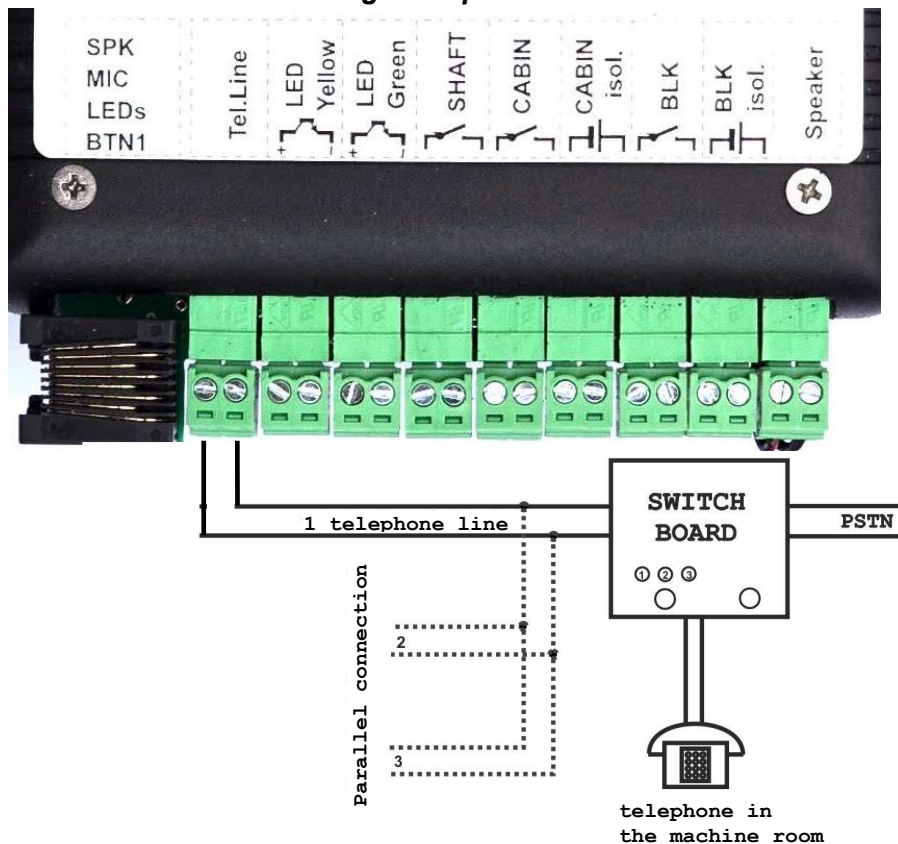

The connector for phonenumber has two wires, even when using a switch in the machine room (SwitchBoard). The switchboard allows you to connect up to 5 communicators in parallel to one line (replaces PBX). The communication protocol ensures that only one communicator is active at a time.

During an outgoing call, the calls of the individual communicators are queued and are handled in the order of the communicators' numbers (addresses) (1 is handled earlier than 2, etc.).

During an incoming call, the communicators are addressed using DTMF (similar to a branch call). The entire addressing process is handled automatically by SwitchBoard and also by BlackBox in the CallCenter system.

It is essential for the communicator to function properly that the connected exchange, gateway, etc., provides the correct signaling.

Standard frequency used is approx. 425 Hz. Individual types of tones differ in cadence – length of tone, spacing or repetition. By detecting a missing ringtone (call progress tone), the communicator identifies that the counterparty has picked up the call and performs an automatic call confirmation. The detection time is set by the parameter **56**. This method could be problematic when connecting to a GSM gateway due to a long time of establishing a call with GSM networks. The gateway then needs to be operated in a mode where itself provides a ringtone for the duration of the call is established by the network.

A frequency other than 425 Hz is then the reason why the communicator does not hang up when the other party ends the call; You can change it with the parameter **500** – p. 57.

1.4.2 Connecting the SHAFT button

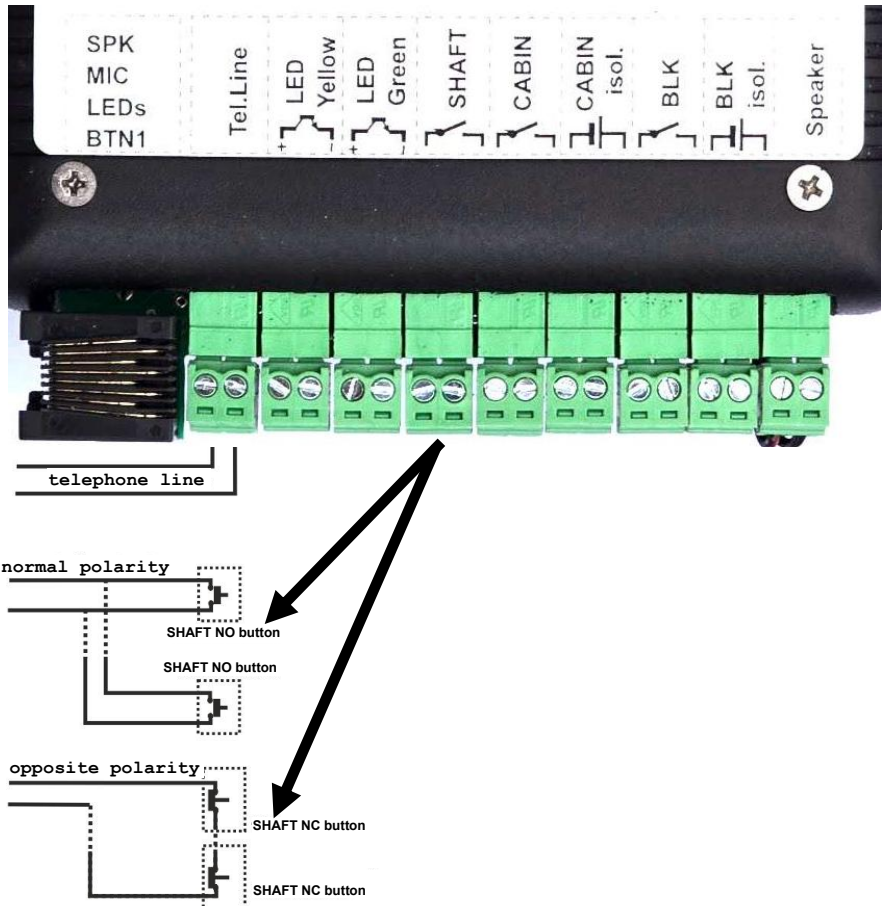

The SHAFT button is a service technician button (not on the elevator car panel - COP). This button is also located on the RJ45 connector for remote connection below/above the cabin.

The connection connector marked SHAFT button is galvanically connected to the telephone line (nothing else must be connected to it).

The function of this button is affected by two parameters – the time of holding the button for activation (parameter **52**) and button polarity (parameter **39**). The polarity of the button allows you to connect a normally closed (NC) or normally open (NO) button types. The NO buttons connect in parallel; the NC buttons connect in series.

The SHAFT button allows three types of calls:

1. *Emergency call* without blocking (works independently of the emergency call blocking setting)
2. Call *End of Emergency* – notification of the presence of a technician on site
3. *Call to the engine room* (using a SwitchBoard) - The phone in the engine room rings and a call is made after pickup

The resolution of the kind of call is determined by using parameter **52**. If the button is pressed for at least the time specified in this parameter, an *Emergency call* is invoked. If the time of pressing the button is 8 times longer than the parameter **52**, the *End of Emergency* call is made. If the **button is pressed 3 times in a row** in a time shorter than parameter **52**, a *Call to the engine room* is made. The explanation is in the picture:

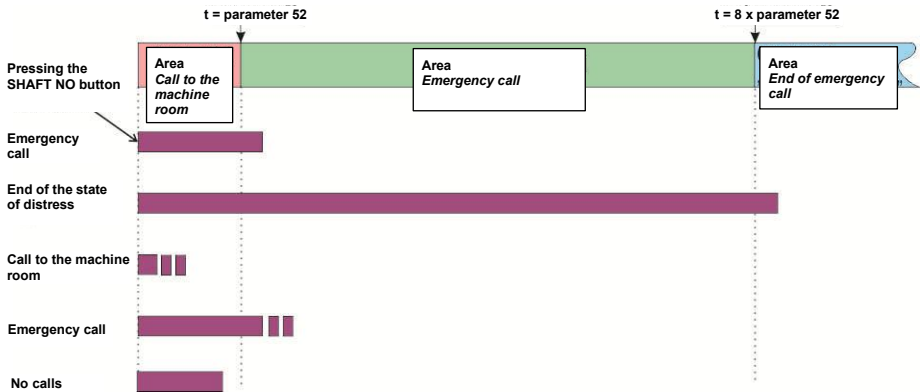

To make a *Call to the engine room*, you need to quickly press the button 3 times. The press time must not exceed the time set in parameter **52**, otherwise an *Emergency call* will be made.

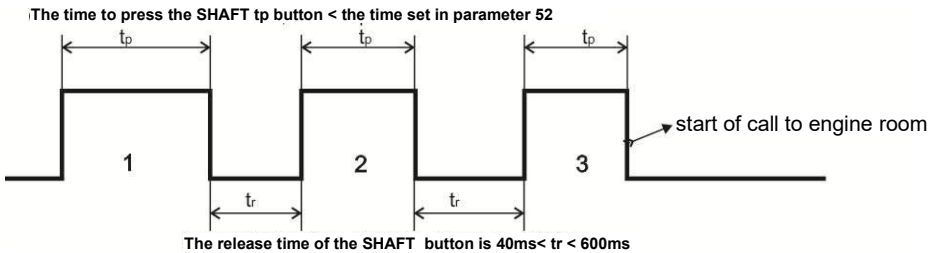

1.4.3

1.4.4 Connecting the CABIN emergency call button

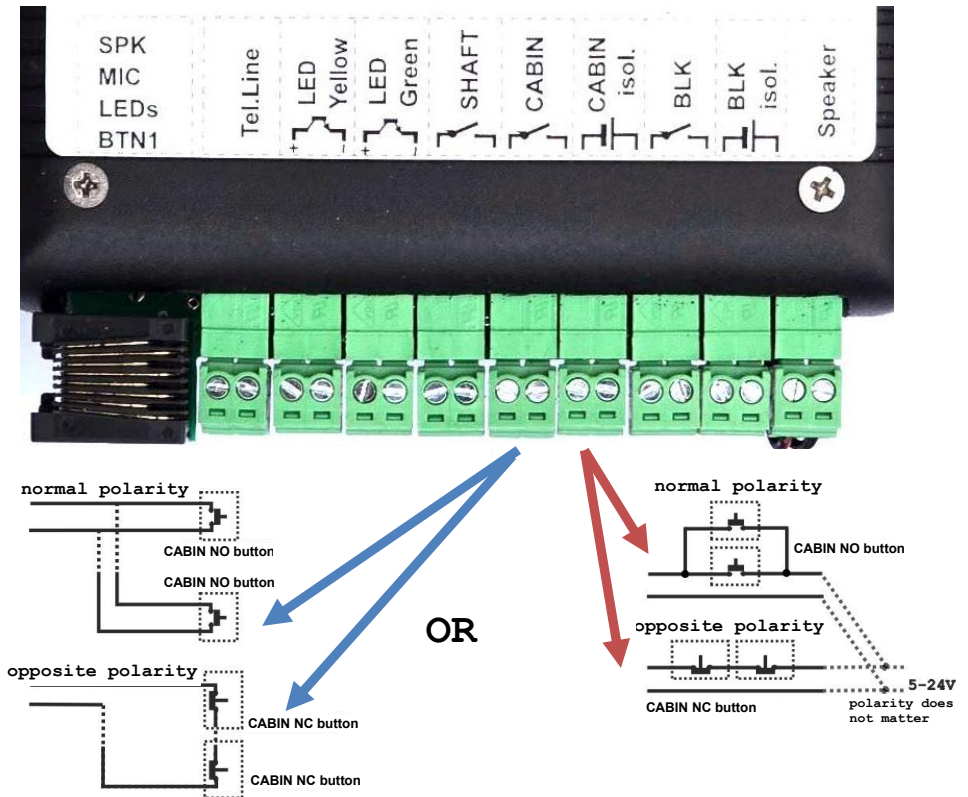

The CABIN button is an emergency call button (placed on the elevator car panel).

The function of this button is affected by two parameters – the time it takes to hold the activation button (parameter **53**) and the polarity of the button (parameter **33**). The polarity of the button allows you to connect a normally closed (NC) or normally open (NO) button types. The NO buttons connect in parallel; the NC buttons connect in series.

The CABIN Button connector is galvanically connected to the telephone line and an isolated button contact is used to activate it (nothing else must be connected to it).

The CABIN isol. connector is an input galvanically isolated by an optocoupler and a voltage of 5 V-24 V is used for activation. This input can be used to connect a siren powered by 12 V/24 V at the same time.

1.4.5 Connecting the indicator LEDs

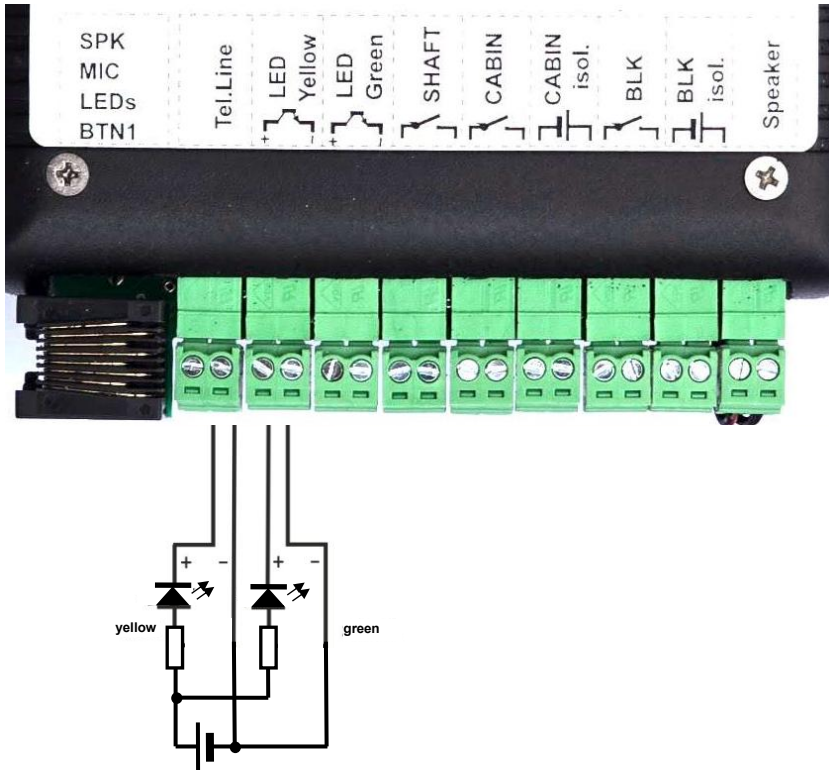

The communicator is equipped with a call status indication. When establishing a connection, the yellow LED lights up, and when the connection is established (the opposite station has picked up), the green LED lights up. For details, see EN81-28:2022. External LEDs are connected to terminals (**beware of polarity!**) LED Yellow and LED Green.



EXTERNAL LEDs ARE NOT POWERED BY THE TELEPHONE LINE.

The LED Yellow and LED Green outputs are galvanically separated by an optocoupler and its output is further enhanced by a transistor. To ensure functionality, it is **ALWAYS** necessary **to connect a suitable current limiting resistor** and an external supply voltage of max 24 V DC. The maximum allowable current is 100 mA.

Without a current-limiting resistor, the transistor/optocoupler will be damaged. Warranty claims will not be accepted!

1.4.6 Connecting the emergency call blocker BLK

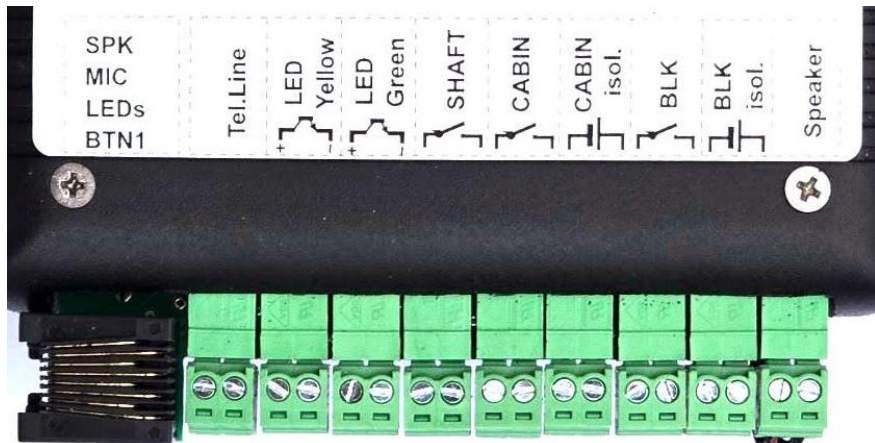

The BLK and BLK isol. connector are used to block the *Emergency Call* initiated by the CABIN button. The blocking can either be derived from a fault condition from the elevator switchboard, or it is possible to activate the automatic blocking function derived from the movement of the door (door switch).

The connector BLK is galvanically connected to the telephone line and an isolated button contact is used for activation (nothing else must be connected to it).

The connector BLK isol. is an input galvanically separated by an optocoupler and a voltage of 5 V-24 V is used for activation.

If the blocking function is not used, then by setting the parameter **34=2**, this input can be used to send information that the technician is present at the elevator. By activating this input, a *Technical call* is made with the DTMF ID code ***1** – *The technician has arrived at the workplace*. After the work is finished, this input is deactivated and a *Technical call* is made with the DTMF ID code ***2** – *Technician has left the workplace*.

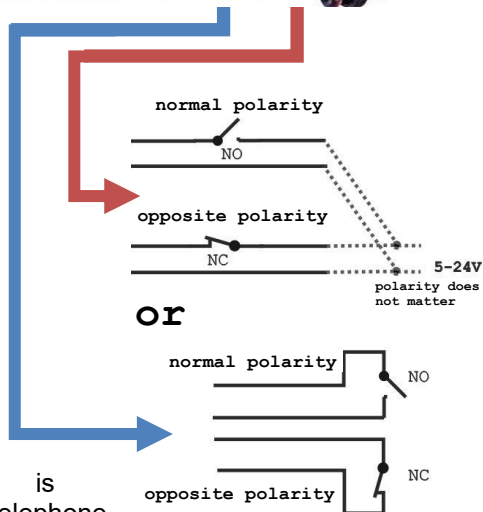

1.4.7 Connection below or above the cab

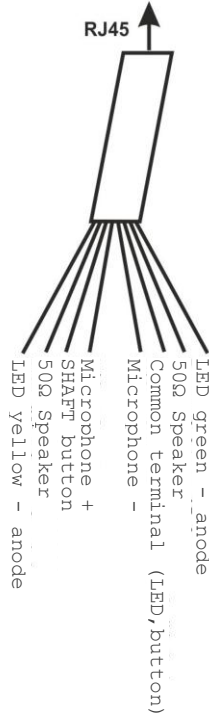

(uc)

Above or below the cab, an LCL SPK device can be connected for communication. RJ-45 connector is used for connection. A standard UTP cable is assumed to be used for connection. Apart from the mechanical requirements imposed by the installation site, there are no special requirements. The following signals are routed through the cable – the speaker (50Ω), microphone (electret – beware of polarity), SHAFT and LED indication (yellow and green).



Be careful to ensure that there is no interconnection to other circuits (e.g. short circuit of the UTP cable to the cab frame) – all signals on RJ45 connectors are galvanically connected to the telephone line and must not be connected to anything else!

1.5 Connecting SwitchBoard

The SwitchBoard is a simple device for communication between the elevator cabin and the machine room.

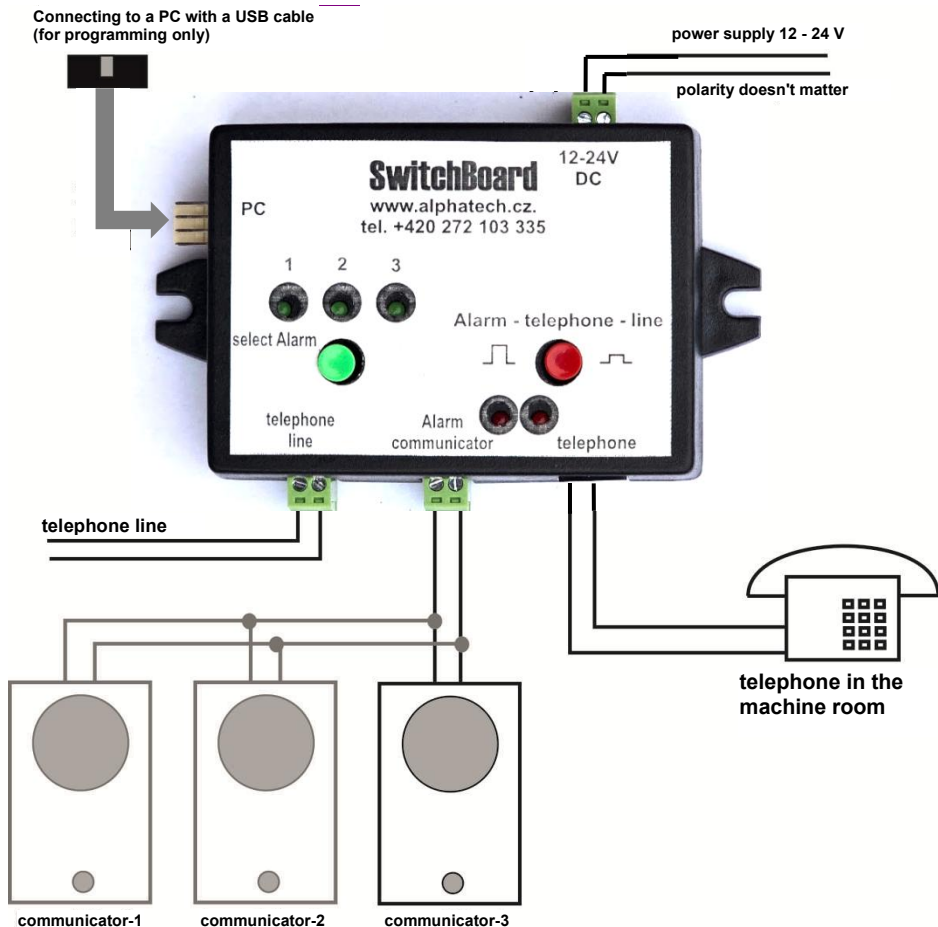

1.5.1 Wiring SwitchBoard

The SwitchBoard plugs in between the telephone line and the communicator (only two wires are used). For proper operation, it is necessary to connect a supply voltage of 12 V to 24 V DC (regardless of polarity). Up to 5 ForesLift Compact communicators can be connected in parallel to one SwitchBoard.

1.5.2 SwitchBoard features

In order for the SwitchBoard to work properly with connected communicators, it must be set up in the same way as connected communicators. The SwitchBoard can be used to connect a single communicator or to connect 2 to 5 communicators connected in parallel (parallel operation).

One communicator:

In this mode, you only need to set four parameters: **45** - parallel mode, **51** - maximum call time, **42** - character to prolong the call, and **43** - hang up code. These four parameters must be set equally in the SwitchBoard and in the ForesLift Compact communicator.

Indication: In *Single Communicator mode*, the green LED No. 1 flashes, the green button does not respond.

Features: When you pick up the handset of a phone connected to the SwitchBoard in the machine room, the phone line disconnects, the phone connects to the communicator, and the SwitchBoard starts ringing until the communicator in the elevator picks up. A normal call is made. If the maximum call time expires, the SwitchBoard will automatically dial the DTMF character to extend the call. If you hang up the phone in the engine room, SwitchBoard will send a DTMF hangup code to the communicator.

Parallel operation:

In this mode, it is necessary to set the selected parameters in the SwitchBoard and all parallel-connected ForesLift Compact communicators. Without the same setting of these parameters, parallel operation will not work. These parameters are: **45** - parallel mode, **51** - maximum call time, **42** - character to prolong the call, **43** - hang up code **4*** - parallel mode constant.

Indication: In *Parallel Operation mode*, the green LEDs indicate the address of the communicator to be called. The address is changed by the green button that switches over and over again these combinations 1 / 2 / 3 / 1+3 / 2+3 / 1+2 / 1+2+3. If the LEDs flash, it is not possible to establish a call (line busy).

The combination of 1+2 works like 3, 1+3 calls communicator 4, 2+3 calls communicator 5.

Function: Select the address of the communicator you want to call with the green button. When you pick up the handset of a phone connected to the SwitchBoard in the machine room, the phone line is disconnected, and the Switchboard begins to establish a connection with the selected communicator. Once the connection is established, a normal call can be made. If the maximum call time expires, the SwitchBoard will automatically dial the DTMF character to extend the call. If you hang up the phone in the machine room, SwitchBoard will send a DTMF hangup code to the communicator.

Red Switch:

A red switch allows you to connect your phone in the machine room directly to the public network line. This will make it possible to call for help in the event of danger or injury, call firefighters or an ambulance.



If the switch is pressed, the SwitchBoard function is disabled (**emergency call from the cabin is disabled!**) and the telephone is directly connected to the PSTN; If the red switch is not pressed, the standard function of communication with elevator communicators is retained and the emergency call from the elevator cabin is also functional.

To make a call from the elevator cabin to the machine room:

The ForesLift Compact elevator communicator is equipped with a function for calling the machine room on a phone connected to the SwitchBoard. This call will be initiated if you press the SHAFT button 3 times for a period shorter than the time set in parameter **52**. (See also p. 14.)

This button is not located on the elevator panel (COP), but is located below or above the cabin on the LCL SPK and also hidden under the panel in the elevator cabin. The SHAFT button is only available to service technicians, not elevator users.

1.5.3 Programming SwitchBoard

The SwitchBoard can only be programmed from a PC, using the LiftConfigurator program, and must be powered by 12 V/24 V. To connect it, it is necessary to use a reduction to the standard 10pin USB connector of the USB-KAB programming cable.

If you have just programmed communicators, save the settings in the LiftConfigurator. Once connected, the SwitchBoard will automatically change in the main menu of the Intercom to the SwitchBoard. Now load the saved parameters from the file where you saved the settings used for communicators and program the Switchboard. We recommend backing up your settings for future service or changes to settings.

Attention! – *the same settings must be written in the communicators and in the SwitchBoard for proper operation!*

Parameters that affect the function:

- 42 Character to prolong the call
- 43 Hang up code
- 45 Parallel/single mode switch
- 4* Constant for parallel mode – time to receive the DTMF address of the communicator
- 51 Maximum call time

Wiring Adapter for connecting the SwitchBoard to a PC



1.5.4 Technical parameters of SwitchBoard

Parameter	Value	Terms and Conditions
Power supply – voltage	12-24 V	DC, polarity doesn't matter
Power supply – current	max. 0.30 A	12 V
	max. 0.18 A	24 V
Current Detection (Line)	min. 8 mA	$U_{line} > 15 V$
Line Current for Communicator(s)	min. 40 mA	
Line Current for Telephone Set	min. 25 mA	
Attenuation line – telephone	<1 dB	1 kHz, 600 Ω
Attenuation communicator – telephone	<3 dB	1 kHz, 600 Ω
Ringling voltage	Min. 55 Vp-p	at 10 mA load
Ringling voltage - waveform	Rectangle	
Dimensions [mm]	112 x 65 x 22	
Operating Temperature	- 20 to + 50 °C	

1.6 Installation

The compact ForesLift Compact solution allows for easy installation in the elevator car panel.



The speaker and microphone are facing the panel

Mounting method on the back of the lift panel (e.g. bolts nailed)

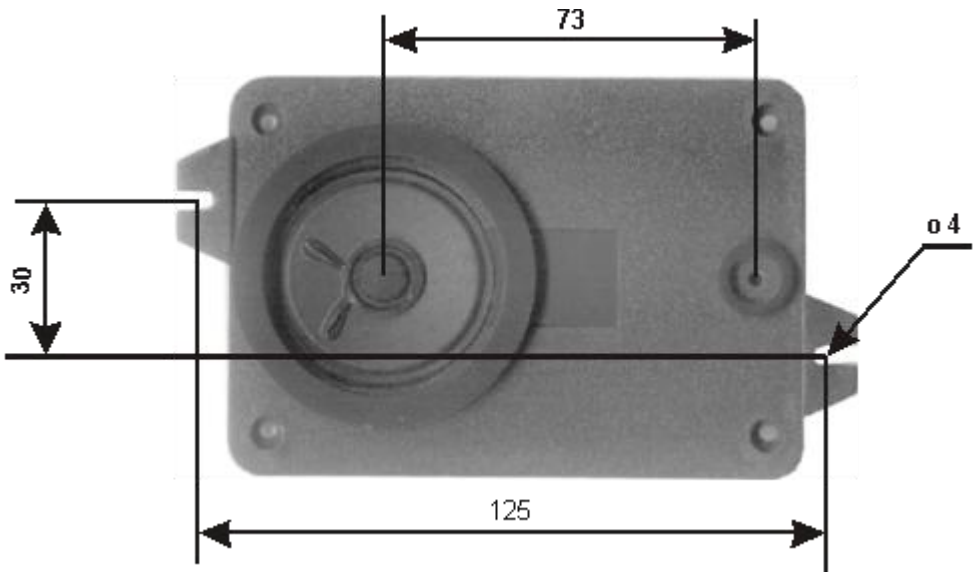

The lift car panel (COP) must include at least two mounting studs M3/M4 (welded bolts), openings for the loudspeaker, and an opening for the microphone. The sealing rings around the loudspeaker and microphone areas must rest firmly and completely against the panel; otherwise, acoustic feedback will occur. The design of the openings (diameter, number of perforations) for both the microphone and the loudspeaker can significantly influence the likelihood of acoustic feedback.

The use of external LEDs requires the connection of a suitable current limiting resistor and power supply.

The communicator is equipped with one RJ45 connector for connecting the LCL-SPK control unit above or below the cabin. This unit includes a SHAFT button, green/yellow LEDs, microphone, speaker.

2. Operation of the ForesLift Compact communicator

The function of the ForesLift Compact communicator is affected by the setting of the communicator parameters (see the chapter on parameter programming p. 42).

2.1 Signaling overview

The ForesLift Compact elevator communicator acoustically signals conditions that may occur during operation. For easier recognition, it usually uses one tone and a combination of different lengths as in Morse code.

Status	Signaling	Comment
Connecting to a Line (Reset)	—■ ■ ■—	Morse "K"
Type 1 - line pickup	—■ ■—	Morse "A"
Type 1 - hangup line	—■ ■ ■—	Morse "N"
Type 2 - line pickup	—■ ■ ■—	Morse "U"
Type 2 - hangup line	—■ ■ ■ ■—	Morse "D"
Empty memory (no number set)	—■ ■ ■ ■—	Morse "H"
Ticking into a call	— —	Very short beeps
Call End Alert	—■ ■ ■—	Morse "S"
Entering programming mode	—■ ■ ■ ■—	4 commas (Morse Ch)
Audio prompt in programming mode	—■ ■—	Two modulated beeps
Command or parameter received	—■■■■■■—	Very long comma
Command or parameter rejected	—■ ■ ■ ■—	Morse "5"

If there is a problem with the installation, it is good to know what tones the communicator plays, because it is easier to analyze the status of the communicator and its operation. The signaling can be switched on/off in several levels (parameters **61**, **62**, **63**, and **65**).

2.2 Calling from the communicator

The ForesLift Compact communicator uses four categories of calls. Each category uses its own phone numbers. During the dialing sequence, they are called sequentially (if there are more than one) and if a redial is set, they are called again until the number of redials is exhausted.

Each call can be confirmed automatically (after being picked up by the callee) or manually, when the callee enters a confirmation code during the call. Even if automatic confirmation is selected, the call can be confirmed by a confirmation code. Call confirmation is indicated by the illumination of the green LED. If the call has not been confirmed, the dialing sequence continues with the next number. If confirmed, the dialing sequence is terminated.

2.2.1 Emergency call

Emergency calling is the basic function of the ForesLift Compact communicator. The call is activated by pressing the CABIN or SHAFT button. The main difference between the buttons is that the SHAFT cannot be blocked by the BLK input, and also the SHAFT button has more service functions. The SHAFT button is not intended for use in an elevator car. Only the CABIN button is intended for emergency calls from the elevator cabin.

Each button has the option to set parameters – the minimum press time to activate the call and the polarity of the button (NO Normally Open / NC Normally Closed).

To make an emergency call using the **CABIN** button, the following three conditions must be met:

- 1): Emergency-call blocking from the BLK input is not active. Pay attention to the setting of the parameters of the BLK input, because the blocking is active even if you set the polarity of the BLK (NC) input, i.e. the closed contact and do not connect anything to the input!
- 2): Setting the correct polarity of the button. The setting of parameter **33** must match the type of button you are connecting (NO/NC)
- 3): The CABIN button must be pressed for at least the time specified by parameter **53**.

To make an emergency call using the **SHAFT** button, the following two conditions must be met:

- 1): Setting the correct polarity of the button. The setting of parameter **39** must match the type of button you are connecting (NO/NC)
- 2): The SHAFT button must be pressed for the time specified by parameter **52**. But at the same time, it must not be held longer than eight times this time, because then the technical call *End of Emergency* (see below) would be triggered.

When connecting communicators in parallel, the call can only take place if the line is not occupied by another communicator. Otherwise, the call will be queued if the previous conditions are met and will take place only after the line is released.

The yellow LED is lit while **the emergency call is being established.** If the communicator is not in the mode according to EN 8128:2022 (see parameter 011), the yellow LED will turn off and **the green LED will light up after confirming the connection.** In EN81-28:2022 mode, **the yellow LED remains lit** until the end of the Alarm state, e.g. reported by a technician from site.

Six phone number memories **are available for emergency calls.** The dialing sequence starts at position 1 and ends either at the sixth position or at the first position where the phone number is not stored. This means that if memory 2 is empty and the following memory is filled, then only the phone number from the first memory will be dialed. The dialing sequence can be repeated up to 9 times according to the parameter **35** setting.

Since the start of the emergency call sequence, the communicator does not respond to the next **button press.** This applies only to the end of the dialing sequence either by establishing a call or by exhausting the redial counter.

2.2.2 Emergency call with blocking

For the button CABIN (button in the elevator car) is available a blocking function. Blocking is available as:

1. direct blocking – the call is dependent on the state of the BLK signal (pay attention to the correct polarity – see parameter **34**). The signal for blocking is derived from the fault signal from the elevator switchboard.
2. timer blocking – activating the BLK signal, e.g. from a door switch, starts the timer for the time set by the **5#** parameter. During this time, an emergency call cannot be made.

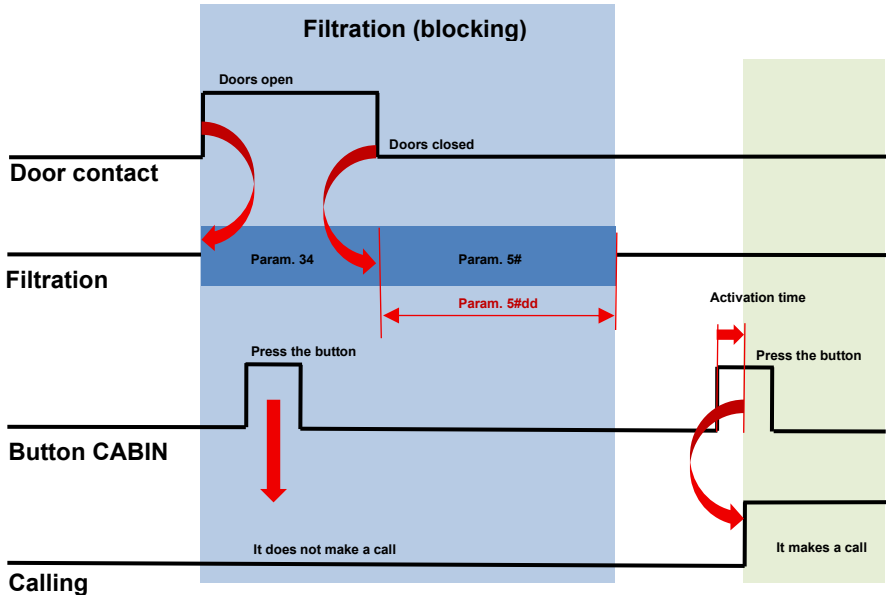

2.2.3 Service call (based on timer)

The service call is an optional parameter. This call can be **enabled**, or **enabled with a first-startup call** during installation, using parameter **31**. The service call is adjustable with a period of 01-59 days. For example, setting 03 means that the communicator calls automatically every 3 days. This call is used to confirm the functionality of the communicator. At the same time as this test, a microphone and speaker check can take place.

If **enabled with a first-startup call** is selected, the communicator will initiate a service call once it is connected to the line.

The service call is with **a lower priority**, so when the emergency call button is pressed, the emergency call is immediately handled and the service call continues after the emergency call is finished.

The service call is repeated until **it is confirmed** (either by a confirmation code or automatically as in the case of emergency calls) or until the number of repetitions is exhausted – parameter **38**.

The redial of the service call does not happen immediately, but after the time delay has elapsed (for easier operation on the CallCenter), this time period is adjustable by parameter **32**.

No LED is lit during a service call and the sound may be suppressed as it is not a voice call.

Automatic acoustic path test – performed either on request by a confirmation command – confirmation code in parameter **07** (making a service call) or automatically, but two conditions must be met:

1. Turn on the automatic acoustic path test function – Parameter **019**
2. Turn on the service call functionality by parameter **31**

Then an acoustic test is performed automatically before the actual service call.

A fault in the acoustic path is reported by an error call with the DTMF ID "0".

2.2.4 Technical calls

A technical call is a special call specifying the technical condition of communicator. One phone number is reserved for this call, and since it can be initiated by multiple events, the type of technical call is distinguished by DTMF by the answer to the DTMF fixed query code ***#***.

End of Emergency call (returns DTMF A). This call is initiated by holding the SHAFT button for a long time (under the panel) – the holding time of the SHAFT button must be longer than eight times the activation time of the SHAFT button (8x parameter **52**).

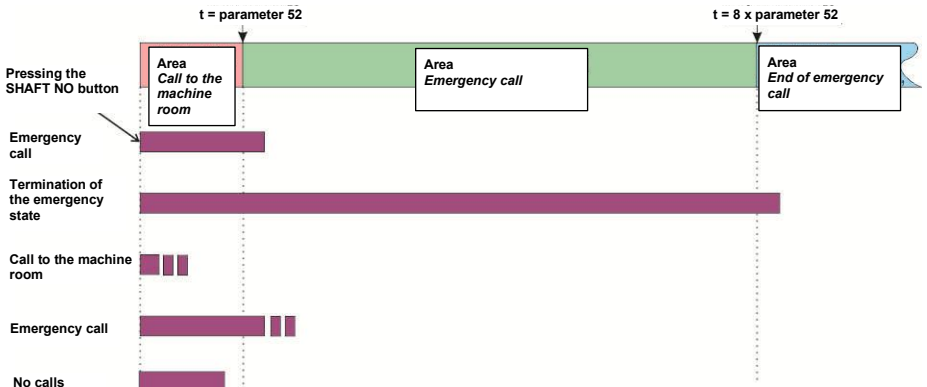

The call is intended for a technician who arrives at the scene to confirm presence at the scene. The use is mainly in connection with the CallCenter.

2.2.5 Error call

Error call triggered when the acoustic path is faulty (returns DTMF 0). If the acoustic-path test (par. 019) is enabled and service calls (par. 31) are active, an acoustic test is performed before the service call. If the test result is negative, an error call is initiated instead.

Error call triggered by a stuck button (returns DTMF 7). If this function is enabled (par. 01*), then at the end of any call, the state of the buttons (with respect to polarity) and the blocking input is tested, if it is in a mode in which it acts as an indicator of the presence of the technician (parameter 34=2). If the button is active, this error call is executed. **The communicator continues to receive calls and also makes service calls.**

2.2.6 Call Confirmation

When using the ForesLift Compact communicator, it is important to find out for each call whether it has taken place (i.e. whether the communicator has called and the call has been answered). Because the analog line does not transmit a pickup signal, the ForesLift Compact includes a call confirmation system. For each phone number, it is possible to set whether the confirmation is done automatically or the call must be confirmed explicitly - "manually". This is done by a set of confirmation codes that the counterparty can use to confirm the call by dialing a group of DTMF codes into the call. The communicator can also detect the counterparty's pick-up automatically by detecting the loss of ringtone. As soon as this happens, it considers such a call to be confirmed. This method has several pitfalls. The first issue is that the confirmation may occur only after the ringing-signal period has elapsed. This period is usually 5 sec (parameter 56), so if the call is picked up by the counterparty and hung up within 5 sec, the call is not confirmed and communicator continues to the

next number. The second problem is that this tone can be reproduced by a voice during the call. In such a case, the communicator cannot detect the absence of the ringing tone, and even if the call lasted, for example, 10 seconds, it is not confirmed and the communicator proceeds with the next call.

Additional issues may occur particularly when calling over GSM networks. If automatic confirmation is enabled, the communicator may interpret the call as successfully connected even in situations where the operator replaces the call setup with a voice announcement — for example, the familiar “The called number is not available. Please call later.” — because the ringing tone has disappeared. **If such a case occurs in the sequence of emergency calls, the call to the next number in the sequence will no longer be made!** For this case, it is better to use “manual” confirmation.

The call may be acknowledged before the connection has occurred. In GSM networks, it takes longer to set up a call, and the line can be silent for a long time before a ringtone appears. If the silence is longer than set by parameter **56**, the communicator evaluates this as a loss of ringing signal and considers the connection to be established. Increasing parameter **56** is generally not recommended, as it results in an extended detection period. This becomes particularly problematic when the remote party answers “in the middle of the tone,” causing the entire duration defined by parameter **56** to be treated as part of the call. Consequently, the call must then be prolonged by the same amount. A suitable solution is to use a GSM gateway that can be configured to generate a ringing tone even before the GSM network has actually established the connection.

2.2.7 Confirm a call with a code

The confirmation code consists of a common leading character and one to four additional programmable digits (**Kxxxx**, where **K** is the common character and **xxxx** is 1–4 digits 0-9). For example, if **K=*** and **xxxx=66**, then confirmation occurs by dialing ***66** into the call. At the same time, the confirmation codes serve as commands to perform communicator operations and are set using the following parameters:

- **par. 47** – after confirmation by this code (in the default settings it is **xxxx=66**), the communicator will respond by sending the serial number of the communicator in DTMF tones. Each communicator has a different serial number, so this number is used to distinguish which communicator is calling, e.g. in a parallel connection, when the CLIP information is the same for all parallel connected communicators. The same case occurs when using a PBX.

- **par. 48** – after confirmation with this code (in the default settings it is xxxx=67), the communicator terminates the emergency call status (according to EN81-28:2022 Alarm state)
- **par. 49** – after receiving this confirmation code (in the default settings it is xxxx=68), the communicator hangs up and makes an emergency call in the same way as if the CABIN button was pressed. It is used to check the settings of the communicator.
- **par. 40** – after confirmation by this code (in the default settings it is xxxx=69), the communicator returns DTMF by dialing the last two called numbers (separated by a special DTMF character "D"), the last called number is sent first and then the penultimate number called.
- **par. 07** - after confirmation with this code (in the default settings it is xxxx=65), the communicator hangs up and makes the service call as if the time for this call had passed. It is used to check the communicator settings and also to check the acoustic path (if parameter **019** is active). A service call is made after the time set in parameter **32** and also the execution of service calls has to be turned on – parameter **31**.

The common character of the confirmation codes **K** can be modified, in the default settings it is * and it is possible to choose it from the available characters (0-9,*,#). We recommend that you use a character different from the characters of other codes used in the communicator. For clarification, here is a list of confirmation codes in the basic settings – par.47 = ***66**, par.48 = ***67**, par.49 = ***68**, par.40 = ***69**, par.07 = ***65**.

The last option **to confirm a call** is to use a hang-up code (parameter **43**), because if this code is used, it means that the call has been answered, the connection has actually taken place and the call can therefore be legitimately considered confirmed.

2.2.8 Connection to the machine room

Only two wires are needed to connect between the machine room and the elevator cabin, just like when connecting directly to a telephone line. In the machine room, a SwitchBoard device is inserted into the telephone line feed. The SwitchBoard is powered by a 12 V or 24 V power supply; the polarity does not matter. To communicate from the machine room, you need to connect a telephone device (standard analogue telephone). The SwitchBoard allows you to connect up to 5 ForesLift Compact communicators connected in parallel.

During the connection of the elevator cabin with the machine room, the state line is disconnected – so **be careful to hang up the phone correctly!**

The cabin-machine room connection can be made in two ways:

1. Call from the machine room to the elevator car:
 - a. connection of one communicator – pick up the phone in the machine room and wait for the communicator to be picked up in the cabin
 - b. parallel connection of communicators – select the communicator number with the green button and pick up the phone, wait for the communicator to be picked up in the cabin
2. Call from the cabin to the machine room – press the SHAFT button 3 times in a row. The phone in the machine room starts ringing, after picking up the phone, a connection is made.

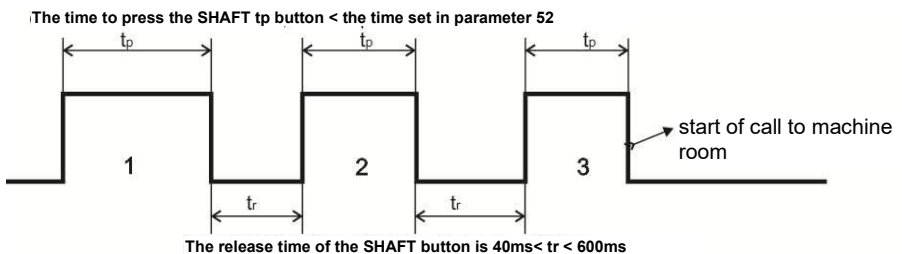

Because the call duration is limited by the communicator (par. 51), the SwitchBoard automatically dials the call prolongation code. When you hang up a call, SwitchBoard automatically sends a hangup code to the communicator.

In order for everything to work properly, it is necessary to set the same parameters in the SwitchBoard and connected communicators. Setting up is done using the LiftConfigurator program – see page 19.

2.2.9 Incoming calls

An incoming call is a call coming to the communicator. After dialing the number of the line to which the communicator is connected, or after picking up the handset of a phone connected to the SwitchBoard, there is a ringing signal on the line to the communicator. The procedure is different if the Switchboard is configured to operate with only one communicator or with several communicators connected in parallel.

When connecting one communicator, the parameter is **45=0** and after the set number of rings (par. **46**), the communicator picks up and the connection is established.

In parallel connection, the parameter is **45=1** and after ringing, it first picks up the communicator with address 1 and then the process of detecting the communicator continues, more is described in the next chapter. After the detection is complete, the selected communicator remains picked up and a call can be made, or the line is hung up.

When a call is received, it is possible to enter the programming mode within the first ten seconds by choosing "#" + „Password" (par. **44**). If the password is not known, connect the SRV jumper (see p. 10 – point 14). If connected, the incoming call enters directly into programming mode, where a programming password (par. **44**) can be set. Do not forget to disconnect the jumper when you are finished!

An incoming call is indicated by a green LED when the line is picked up – a connection is established.

2.2.10 Parallel connection of FLC communicators

This mode is selected by the parameter **45**. After setting the parallel mode, the communicator behaves as follows:

- Before starting an outgoing call, the communicator checks whether the line is occupied by another communicator. In this case, it waits for the line to be released and then makes its own call. Communicators are queued by the communicator's address (par. **46**), i.e. the communicator with a higher address comes later, or it can also be said that the communicator with a lower address has a higher priority.
- The incoming call starts the address detection process in all parallel communicators at the same time with the first ring. A maximum of two communicators are connected to the line at any given time. The principle is shown in the figure:

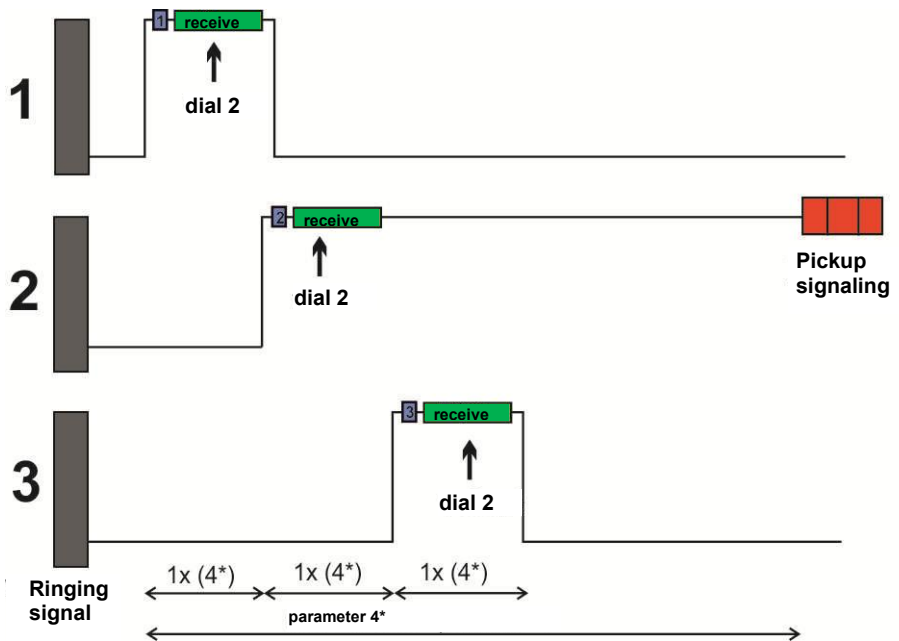

On the left is the address of the communicator. The communicators in the order given by the address gradually pick up the line, announce the pickup by sending their own address via DTMF (1-5) and wait for a response - the address of the called communicator in DTMF. The waiting time is given by the **parameter 4*** (parallel connection constant). If the addresses match, the communicator remains picked up (in the picture it is communicator no. 2). The whole process takes approximately the time given as $5 \times$ the time in parameter 4^* . Therefore, there is a delay of a few seconds between the first pick-up of the line and the call connection, which must be taken into

account. This delay has a fixed length and is given by the maximum possible number of parallel connected communicators (i.e. 5).

Communicator addressing can be done in several ways:

- manually – by selecting DTMF from the phone (then it is recommended to increase the constant **4*** so that you can react comfortably. First you hear a ringtone, then DTMF 1 sounds (you hear the DTMF tone) and you answer with the address of the desired communicator in DTMF. This is repeated according to the number of communicators connected in parallel. Each communicator first sends its DTMF address, thus instructing that it is ready to receive the DTMF address for comparison. After the time given by 5x parameter **4***, the usual pick-up signal of the relevant communicator will sound and the call will take place.
- another option is to use the BlackBox modem in the CallCenter – everything will be done automatically here.
- The last option is to call from the machine room. In SwitchBoard, you set the address of the communicator with the green button – the address is indicated by green LEDs, and then you pick up the phone's handset. The SwitchBoard automatically establishes a connection with the selected communicator.



BEWARE of these possible problems:

- communicators connected in parallel must always form a linked series of addresses, no address must be omitted (e.g. 1-2-3 is correct, it must not be 1-2-4, etc.)
- communicators connected in parallel must not have the same address (e.g. the correct is 1-2-3, it must not be 1-2-2, etc....)
- A VoIP or GSM connection introduces an additional delay, and this must be taken into account when choosing the **4*** value.

2.2.11 Call Center and Call Types

Each type of call has its own identification code (ID) in DTMF, which the communicator returns to **the query **** entered during the call. This is mainly used for technical and error calls that use the same phone number for calls for multiple reasons.

Related parameter	Event	Call Type	DTMF ID Code
11	Emergency call 1	Emergency call	1
12	Emergency call 2	Emergency call	2
13	Emergency call 3	Emergency call	3
14	Emergency call 4	Emergency call	4
15	Emergency call 5	Emergency call	5
16	Emergency call 6	Emergency call	6
21	Service calls	Service calls	8
-	Ending the emergency call status (ALARM status)	Technical calls	A
019	Acoustic Test Error	Error call	0
01*	Button Permanently Pressed	Error call	7
34 4	Technician present on site	Technical calls	*1
34 4	Technician left the site	Technical calls	*2

Technical calls use the phone number set by parameter 22.

Error calls use the phone number set by parameter 23.

3. Parameter programming

3.1 Programming with your phone

From the phone – all parameters of the ForesLift Compact communicator can be programmed using the DTMF option. It is not possible to program the SwitchBoard, it can only be programmed from the PC program LiftConfigurator.

3.1.1 Entering programming mode

The ForesLift Line communicator can be put into programming mode in two ways:

1. **using a password** – Incoming call only! – pick up the phone and dial the number where the communicator is connected. The communicator picks up (you hear the pick-up tone – see chapter 2.1 p. 25) enter **#xxxx**, where xxxx is the service password for accessing programming (*in the default settings xxxx=0000, then you choose "#0000"*), if the password is correct, the tone of entering the programming mode is heard, and then the sound prompt of the programming mode is heard (see chapter 2.1 p. 25). **The programming mode can only be entered about 10 seconds after the start of the connection with the communicator!**
2. **using a jumper "SRV"** – incoming call only! – connect to the communicator according to point 1, but if the SRV jumper is connected, the communicator goes straight into programming mode after picking up without the need to enter a password – you hear the pick-up tone, the tone of entering the programming mode and then you hear the sound prompt of the programming mode (see chapter 2.1 p. 25).

Do not forget to disconnect the SRV jumper in the end!

3.1.2 Parameter programming

The default state for programming is indicated by an audible prompt of the programming mode. The communicator returns to this state every time (5 seconds) no matter what you start to set.

Parameters are not terminated by any special character. Parameters **with fixed length** (the vast majority) are accepted (rejected) as soon as the mandatory length is reached. Confirmation or rejection is indicated by different tones (see chapter 2.1 p. 25). Parameters **with variable length** (*Parameter 1, 2, 47, 48, 49, 40, 07 i.e. phone numbers and confirmation codes*), are accepted/rejected after the inactivity time (5 sec) has elapsed, or immediately if they reach the maximum length; for *parameters 1 and 2* it is 16 characters, for *parameters 47, 48, 49, 40, 07* it is 4 characters.

If you enter a character that is not allowed at certain position during programming (e.g. a value out of range, etc.), the command is rejected immediately – the communicator sends **an error tone**, the parameter is not

written or changed, the communicator goes to the default state and it is possible to repeat setting the parameter or program another one.

The communicator stays in programming mode for 2 minutes, then automatically hangs up. With each DTMF tone you dial, this timeout is always reset. The programming mode can be exited by selecting parameter **9** (immediately) or by hanging up – the communicator hangs up after a specified number of tones (par. **58**).

3.2 Programming from a PC – LiftConfigurator

For setting up communicator using a personal computer (PC), it's necessary to have a special USB-KAB cable and the LiftConfigurator program, and it is also necessary to have communicator connected to a telephone line.

Procedure:

- Connect the communicator to the line
- Connect the communicator to PC using USB-KAB. The communicator picks up the line, an **Entering programming mode** tone sounds (see chapter 2.1 p.25), the green and yellow LEDs start flashing together.
- Start the LiftConfigurator program. During the operation of the LiftConfigurator program, the communicator is in programming mode and until the USB cable is disconnected from the communicator, it does not perform any other activity. If the connection is lost, it is necessary to disconnect the cable from the communicator, wait for the communicator to restart (at the earliest in about 5 seconds), reconnect the cable – the communicator will try to re-establish the connection.
- If the driver for USB-KAB is installed correctly, *OK-Alarm* is written at the bottom left of the status bar.
- Establishing a connection between the communicator and the PC program is indicated in the upper right, where the name of the device that is connected to the PC program appears. The firmware version and the number of resets are loaded and displayed on the status bar. Next, the serial number and the time remaining until the next service call (top left) are read. In the Comfort version, the voltage of the external power supply (if connected) also appears after a while.

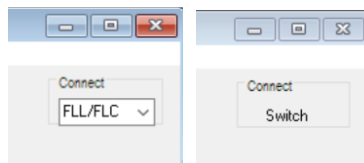

For easy orientation, the parameters in the LiftConfigurator are marked with the same codes used when programming from the phone (see chapter 4 – p. 42), which makes it easier to navigate.



USB-KAB is a special USB cable with galvanic isolation and converter. Galvanic isolation is necessary because the telephone line must not be grounded and the PC is usually grounded via the power supply.

3.2.1 Programming SwitchBoard

SwitchBoard can only be programmed from a PC, from a program LiftConfigurator. The SwitchBoard has a connector for connecting a PC with only 4 pins, so it is necessary to use an adapter for the standard 10-pin USB connector of the USB-KAB programming cable. Programming is easy, in the program LiftConfigurator you already have the settings you used for the communicator. After connecting the SwitchBoard, the detected device will be automatically displayed (SwitchBoard – top right) and now you just need to write these parameters into the SwitchBoard. The SwitchBoard must be powered by 12V/24V. We recommend saving this setting on your PC for future service or setting changes.



Attention – *the same settings must be written in the communicator(s) and in the SwitchBoard for proper operation!*

3.3 Installing LiftConfigurator

Program LiftConfigurator is designed to be installed on the Windows operating system and can be installed from Window98SE to Windows11.

Procedure:

- if you have a program downloaded from www.alphatech-cz.eu , it is compressed in a ZIP package and you need to unzip it first.
- Click on the "setup.exe" file
- Choose the installation language if the one offered does not suit you
- We recommend installing as offered in the installer (i.e. agree to the offers when the installation is complete)
- The LiftConfigurator icon will appear on the desktop, and when clicked, the program will start.

The program allows you to record operations and events in a LOG_comm_file.TXT file (in the installation folder). If there is any problem, please attach this file to the email describing the problem.

For the USB-to-KAB USB cable, it is necessary to install **USB Driver**. After connecting the cable to the PC, you will be prompted to install the driver, **Use only the driver [USB-Driver-64-bit](http://www.alphatech-cz.eu/en/support-alphatech)** from the site <https://www.alphatech-cz.eu/en/support-alphatech> and not the driver that Windows installs automatically!



The driver is not electronically signed, you must use the instructions for installing an unsigned driver:

[USB-PC-Driver-Update-Cable-W10-W11](http://www.alphatech-cz.eu/en/support-alphatech) on the page <https://www.alphatech-cz.eu/en/support-alphatech> .

The LiftConfigurator program with a USB cable can also be used to **upgrade the firmware** in the FLL communicator.

You can find the LiftConfigurator program on the website of the manufacturer <https://www.alphatech-cz.eu/en/foreslift-line-lift-intercom> .

In the LiftConfigurator, the connected device is displayed in the upper right corner:

- FLL/FLC (communicator)
- Switch (SwitchBoard)

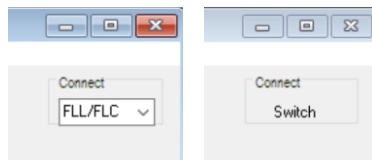

4. Parameter Description

The meaning of the symbols in the following tables:

- d** – digits 0..9 – the range depends on the parameter
- n** – natural number 1..9 – the range depends on the parameter
- b** – bit value 0/1
- c** – character 0..9, #, * – the range depends on the parameter

4.1 Phone numbers

Phone numbers are not deleted by setting device to default (command 8##), they can be deleted using command 81 for emergency phone numbers and command 82 for other phone numbers.

Emergency phone numbers (push button activation)

Parameter	Value	Description	Default
1	nb cc...	Phone number cc in order n with confirmation b	-

n – order of the phone number in memory, enter [1-6]

b – call confirmation, enter [0-1], 0 without confirmation, 1-with confirmation

cc – Phone number 16 digits max. To enter *, Pause, use the table. Because there are 12 buttons on the dial pad of the phone and it is usually necessary to enter a Pause to select it, the method where * is used as prefix. Then * is entered as ** and Pause as *0.

Function	Input
0–9	0–9
#	#
*	**
Pause	*0

Phone numbers are not deleted by setting device to default; there is a special command 81 to delete all numbers for emergency calls.

Example: in the first position you want the communicator to call this phone number: **0P213658 without confirmation** and in the second position you want to call **54*23#78P914 with confirmation**, then the programming sequence for the first position is: 110 0*0213658, wait for the confirmation tone, then for the second position dial 121 54**23#78*0914 and wait for the confirmation tone.

Example: **Deleting** the emergency phone number, e.g. in the second position – then dial sequence **12** and wait for the confirmation tone.

Service call phone number

Parameter	Value	Description	Default
21	b cc...	Phone number cc with confirmation b	-

b – call confirmation, enter [0-1], 0 without confirmation, 1-with confirmation

cc – Phone number 16 digits max. To enter *, Pause, use the table. Because there are 12 buttons on the dial pad of the phone and it is usually necessary to enter a Pause to select it, the method where * is used as prefix. Then * is entered as ** and Pause as *0.

Function	Input
0–9	0–9
#	#
*	**
Pause	*0

Phone numbers are not deleted by setting device to default, there is a special command **82** to delete all numbers except emergency numbers.

Example: you want the communicator to call this phone number: **0P123456789 without confirmation**, then the programming sequence is: 210 0*0123456789 and wait for the confirmation tone.

Example: Clearing the phone number of service calls – then dial sequence **21** and wait for the confirmation tone.

Phone number for technical calls

Parameter	Value	Description	Default
22	b cc...	Phone number cc with confirmation b	-

b – call confirmation, enter [0-1], 0 without confirmation, 1 - with confirmation

cc – Phone number 16 digits max. To enter *, Pause, use the table. Because there are 12 buttons on the dial pad of the phone and it is usually necessary to enter a Pause to select it, the method where * is used as prefix. Then * is entered as ** and Pause as *0.

Function	Input
0–9	0–9
#	#
*	**
Pause	*0

Phone numbers are not deleted by setting device to default; there is a special command **82** to delete all numbers except emergency numbers.

Example: you want the communicator to call this phone number: **789 with confirmation**, then the programming sequence is: 221 789 and wait for the acknowledgment tone.

Example: Clearing the phone number of technical calls – then dial sequence **22** and wait for the confirmation tone.

Phone number for error calls

Parameter	Value	Description	Default
23	b cc...	Phone number cc with confirmation b	-

b – call confirmation, enter [0-1], 0 without confirmation, 1-with confirmation

cc – Phone number 16 digits max. To enter *, Pause, use the table. Because there are 12 buttons on the dial pad of the phone and it is usually necessary to enter a Pause to select it, the method where * is used as prefix. Then * is entered as ** and Pause as *0.

Function	Input
0–9	0–9
#	#
*	**
Pause	*0

Phone numbers are not deleted by setting device to default; there is a special **command 82** to delete all numbers except emergency numbers.

Example: you want the communicator to call this phone number: ***22 without confirmation**, then the programming sequence is: 230 **22 and wait for the confirmation tone.

Example: Clearing the phone number of error calls – then dial sequence **23** and wait for the confirmation tone.

4.2 Elevator operation

Parameter	Value	Description	Default
31	d	Service call state (0/1/2)	0

- d** – **0** Service call turned off
- **1** Enabled service call after time in parameter **59**
 - **2** Enabled service call after time in parameter **59** and it is also activated when connecting to the line for the first time

The service call is activated after the time set in parameter **59** has elapsed. Failed call is redialed after the delay set in parameter **32** until the number of redials is exhausted (par. **38**).

Note: before the service call, acoustic path can be tested (see par. **019**)

Parameter	Value	Description	Default
32	d	Service call retry time [min] (0..9)	4

- d** – **0 ÷ 9** – A failed service call is retried after a time of 0 ÷ 9 minutes. This time is adjustable so that repeated service calls from a larger number of communicators do not come at the same time. 0=Called immediately – without delay.

Parameter	Value	Description	Default
33	b	Polarity of the CABIN button (in the cabin) (0/1)	0

- b** – **0** a button with normal polarity is connected (type NO – normally open, buttons are connected in parallel)
- **1** a button with opposite polarity is connected (NC type – normally closed, buttons are connected in series)

The button can be connected to the CABIN button input, then only a galvanically isolated contact can be used without connection to other devices and voltages.

Or the button can be connected to the CABIN isol. input, then the button is connected in a circuit with a voltage of 5 V – 24 V, then the voltage at the CABIN isol. input is decisive. Normal polarity then means that when the button is pressed, a voltage of 5 V – 24 V should appear on the CABIN isol. input.

Parameter	Value	Description	Default
34	d	Polarity of the BLK input (0/1/2/3/4)	0

- d** – **0,2** a button with normal polarity is connected (type NO – normally open, buttons are connected in parallel)
- **1,3** a button with opposite polarity is connected (NC type – normally closed, buttons are connected in series)
- **4** Call blocking is disabled and the blocking input is used to send information about the presence of a technician on the elevator using a technical call

The button can be connected to the BLK input, then only a galvanically isolated contact can be connected **without** connection to other devices and voltage.

Or the button can be connected to the BLK isol. input, then the button is connected in a circuit with a voltage of 5 V – 24 V, then the voltage at the BLK isol. input is decisive. Normal polarity then means that when the contact is switched on, a voltage of 5V – 24V should appear on the BLK isol. input.

Parameter	Value	Description	Default
35	n	Number of emergency calls redials (1-9)	3

- n** – **1 ÷ 9** times is repeated the entire sequence of emergency numbers (since the button was pressed). One sequence means dialing emergency phone numbers from the first position to the empty or sixth position. Parameter value **n** indicates the number of times this sequence will be repeated. The entire dialing cycle ends either with the call confirmation (green LED illuminated) or with the sequence counter **n** running out.

Parameter	Value	Description	Default
36	n	Number of technical calls repeated (1-9)	1

- n** – **1 ÷ 9** times is repeated the dialing of the technical phone. There are five types of technical calls, the explanation is on p. 29

Parameter	Value	Description	Default
37	n	Number of error calls repeated (1-9)	1

- n** – **1 ÷ 9** times is repeated the dialing of the phone number for error calls - the explanation is on p. 30

Parameter	Value	Description	Default
38	dd	Number of service call redials (00-99)	00

dd – 00 ÷ 99 The service call phone number can be redialed up to 99 times. (The service call is invoked from the internal timer and the retry period is adjustable by the **59** for 01-59 days.

Parameter	Value	Description	Default
39	b	Polarity of the SHAFT button (for service purposes) (0/1)	0

b – 0 a button with normal polarity is connected (type NO – normally open, buttons are connected in parallel)
– 1 a button with opposite polarity is connected (NC type – normally closed, buttons connect in series)

The button can be connected to the input of the SHAFT button, then only a galvanically isolated buttons can be connected **without** connection to other devices and voltages.



The button can also be connected to wires SHAFT on RJ45 connector. In this case, only a galvanically isolated button may be connected **without** connection to other devices and voltage, see p. 18. The SHAFT input on the RJ45 connector is connected in parallel with the SHAFT button connector. If they are to be used at the same time, all buttons connected to the SHAFT input of type NO (normally open) must be used. Module **LCL-SPK** is equipped with a button of the NO type.

4.3 Basic parameters

This feature is not implemented in the current firmware.

Parameter	Value	Meaning	Default
41	b	Confirm a call by reversing the polarity of the line (0/1)	0

- b – Call Confirmation b=0 Automatic call confirmation based on ringtone loss detection, b=1 automatic call confirmation based on the change in line polarity (the function of rotating the polarity of the line must also be available on the device to which the ForesLift-Line communicator is connected)

Parameter	Value	Meaning	Default
42	c	Call prolongation character (* / #)	*

- c – Call prolongation character * or # (About 15 seconds before the end of the call, the communicator sends a notification (see p. 25), then the call can be prolonged)

Parameter	Value	Meaning	Default
43	cd	Command to hang up the communicator from the phone (00-99,*0-*9)	44

- cd – command to hang up the communicator from the phone [2 places]
The command is always programmed as two digits, but if you want to hangup by only **one digit** command, there is an option to enter "***d**" where **d** is only one digit, which causes the switch to be switched on (the asterisk represents an empty character and must be in the first place).

Example: you want to hangup by 4, the programming sequence is **43 *4**.

Parameter	Value	Meaning	Default
44	dddd	Service password (0000-9999)	0000

- dddd – Service password for entering programming mode using the phone (DTMF)



If you forgot the password, then the following procedure is recommended:

1. connect jumper SRV (see p. 10 – point 14)
2. Call the communicator
3. After picking up the line, the communicator is in programming mode. In this mode, you can change the password with the **44xxxx command to a new password**
4. disconnect the SRV jumper (see p. 10 – point 14)

Parameter	Value	Description	Default
45	b	Turn on parallel mode (0/1)	0

b – 0 parallel mode is disabled
 – 1 parallel mode is enabled, up to 5 communicators can be connected in parallel per SwitchBoard. Related to parameter settings **46 a 4***.

Parameter	Value	Description	Default
46	n	Number of rings before the communicator picks up / communicator number in parallel mode (1-5)	3

n – 1 ÷ 5 in normal mode (not parallel) means **n** the number of rings before the communicator picks up the line.

In multi-communicator parallel mode, **n** stands for the communicator address. In parallel mode, two rules must be followed:

1. Each communicator must have a different number **n**, it must not be the same!
2. communicator numbers start with 1 and the number must not be omitted between them (for 3 parallel communicators 1-2-3 is correct, 1-3-4 or 1-2-4 is incorrect)

Parameter	Value	Description	Default
4*	dd	Constant for parallel mode – time to receive the DTMF address of the communicator (10-49)	25

dd – 10 ÷ 49 During this time, the communicator address (DTMF) is received in parallel mode. This time is needed to select the address of the communicator, but it also prolongs the whole process of detecting which communicator should pick up an incoming call [2 places]

The time of the constant is entered in tenths of a second, i.e. **dd=10** is 1 sec, **25** is 2.5 sec. The explanation of the meaning of the constant is on the page35.

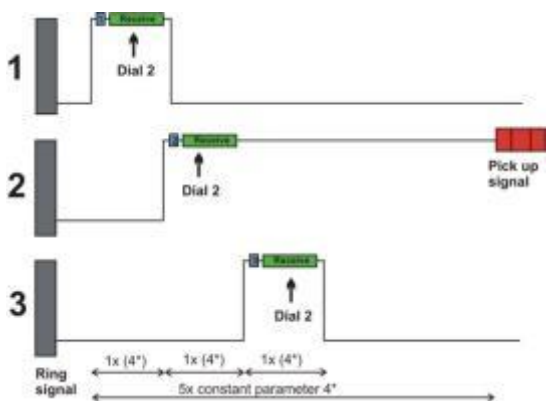

Parameter	Value	Description	Default
47	dddd	Confirmation code – the communicator returns the serial number (0-9999)	66

dddd – Confirmation code [1-4 places] – confirms the call (authorization), the communicator returns its' serial number (six digits each) in DTMF after receiving this confirmation code.

During a call this code can be dialed from the phone or from the Call Center, this confirmation authorizes the call, the green LED lights up.

You can use a code 1-4 digits long, but be careful, when using a confirmation code, it is preceded by a common character K (parameter **4#**).

Example: the common sign for confirmation will be * and the confirmation character (for serial number) will be **66**, then the programming sequence is **4# *** you hear the confirmation by tone, then **47 by 66** and you will wait for the confirmation by tone. The confirmation code is then dialed **"*66"** during the call.

Parameter	Value	Description	Default
48	dddd	Confirmation code – the communicator ends the ALARM status (0-9999)	67

dddd – Confirmation code [1-4 places] – confirms the call (authorization), the communicator ends the ALARM state created by pressing the emergency call button in the cabin. It is especially useful when calling a false emergency call by mistake, when moving, etc.

During a call this code can be dialed from the phone or from the Call Center, this confirmation authorizes the call, the green LED lights up and the yellow LED goes OFF.

You can use a code 1-4 digits long, but be careful, when using a confirmation code, it is preceded by a common character K (parameter **4#**).

For example: Common sign for confirmation from the previous example * (p. 50) and the confirmation sign (for ending Alarm status) will be **8**, then the programming sequence is **48 8** and wait for a tone confirmation. The confirmation code is then dialed **"*8"**.

Parameter	Value	Description	Default
49	dddd	Confirmation code – the communicator hangs up and makes an emergency call as if the SHAFT button was pressed (0-9999)	68

dddd – Confirmation code [1-4 places] – confirms the call (authorization), hangs up the communicator and in 10 s starts the emergency call sequence as if the SHAFT button was pressed (i.e. it calls regardless of the state of emergency call blocking with the BLK input).

During a call this code can be dialed from the phone or from the Call Center, this confirmation authorizes the call, the green LED lights up before the call ends, then the yellow LED lights up – the emergency call flag.

You can use a code 1-4 digits long, but be careful, when using a confirmation code, it is preceded by a common character K (parameter **4#**). *For example:* the common sign for confirmation from the previous example * (p. 50) and the confirmation sign (for emergency call control) will be **789**, then the programming sequence is **48789** and wait for a tone confirmation. The confirmation code is then dialed **"*789"**.

Parameter	Value	Description	Default
40	dddd	Confirmation code – the communicator returns the last two called phone numbers (0-9999)	69

dddd – Confirmation code [1-4 places] – confirms the call (authorization), the communicator returns the last two called phone numbers to DTMF after receiving this confirmation code. It returns the last phone number called first, then the separator is "DTMF D" and then the penultimate phone number called. (max. 33 digits).

During a call this code can be dialed from the phone or from the Call Center, this confirmation authorizes the call, the green LED lights up.

You can use a code 1-4 digits long, but be careful, when using a confirmation code, it is preceded by a common character K (parameter **4#**). *For example:* the common sign for confirmation from the previous example * (p. 50) and the confirmation character (for the last numbers called) will be **69**, then the programming sequence is **48 69** and wait for a tone confirmation. The confirmation code is then dialed **"*69"**.

Parameter	Value	Description	Default
07	dddd	Confirmation code – the communicator hangs up and makes a service call (may include an acoustic path test) (0-9999)	65

dddd – Confirmation code [1-4 places] – confirms the call (authorization), hangs up the communicator and starts the service call as if the time for the service call had expired.

Note, the call will only be made if the service call is enabled (par. **31**), the acoustic test shall be carried out only if it is permitted (par. **019**) and the actual service call will be made 10s after hanging.

During a call this code can be dialed from the phone or from the Call Center, this confirmation authorizes the call, the green LED lights up.

You can use a code 1-4 digits long, but be careful, when using a confirmation code, it is preceded by a common character K (parameter **4#**). *For example:* the common sign for confirmation from the previous example * (p. 50) and the confirmation character (for checking the service call) will be **65**, then the programming sequence is **48 65** and wait for a tone confirmation. The confirmation code is then dialed **"*65"**.

Parameter	Value	Description	Default
4#	c	The first common character of confirmation codes (0-9 /* / #)	*

c – The first character of the confirmation codes is common. The confirmation codes are always entered in such a way that the first is a common character and it's followed by a one- to four-digit confirmation code. If, for example, the call confirmation and serial number request has a code **66** and the common character is *, then the confirmation code entered is **"*66"**.

The common character is chosen for easier identification of all commands. It is recommended that you use as common confirmation character a character that is different from the first characters of all other command codes.

4.4 Time parameters

Parameter	Value	Description	Default
51	c	Maximum call duration (0-9,*,#)	4

- c** – The maximum amount of time a call can last. The call can be prolonged during the call by sending a character from the phone (* or # - see parameter **42**). The time is entered according to the table.

Time[min]	Input
0,5	0
1 - 9	1 - 9
15	*
30	#

Parameter	Value	Description	Default
52	dd	Time to hold the SHAFT button to initiate an emergency call (01-30)	02

- dd** – 01 ÷ 30 minimum time [sec] for which the SHAFT button must be pressed to initiate an emergency call. SHAFT button has 3 functions. The parameter **52** is used to distinguish what kind of call should be made – see the image below.

*Note: for "End of Emergency Call", it is necessary to hold the SHAFT button for more than eight times the time given by parameter **52** (8x parameter **52**)*

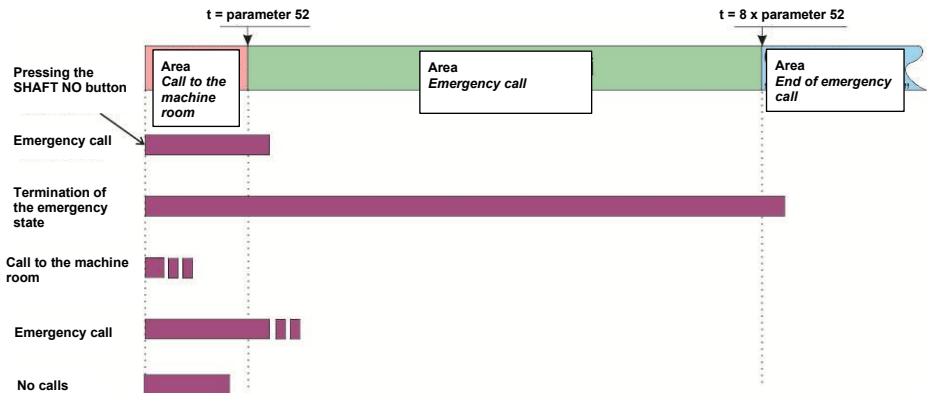

Parameter	Value	Description	Default
53	dd	Time to hold the CABIN button for initiating an emergency call (01-30)	05

- dd** – 01 ÷ 30 minimum time [sec] for which the CABIN button must be pressed to initiate an emergency call.

Parameter	Value	Description	Default
54	n	Hangup time during redial (1-5)	2

n – The time [sec] for which the communicator hangs up before picking up again to repeat the call [range 1-5]

Parameter	Value	Description	Default
55	n	Time before dialing a phone number (1-5)	1

n – Time [sec] after picking up the communicator before dialing a phone number [range 1-5].

This time is different for each phone system / PBX, but as a rule, most phone systems / PBXs can process the dial within 2 seconds after picking up the line.

Parameter	Value	Description	Default
56	n	Time without ringtone – automatic call confirmation (1-0)	5

n – 1 ÷ 10 sec (0 = 10 sec) if no ringtone is detected in this time interval, it means that ringing ended due to pick-up and now it's a talk phase of a call. If the auto-confirm mode is selected, the call is confirmed at this moment i.e. the green LED lights up.

The call is not confirmed, even though it should:

1. The call takes less time than the time set in Par. **56**
2. After a pick up, a ringtone is falsely detected during a talk

The call was confirmed, although it should not:

1. The ringtone period is longer than the time set in Par. **56**
2. The time to establish the connection (there is a silence on the line) is longer than the time set in parameter **56**
3. The operator uses a voice message to notify the operating status – e.g. "The called number is not available..."

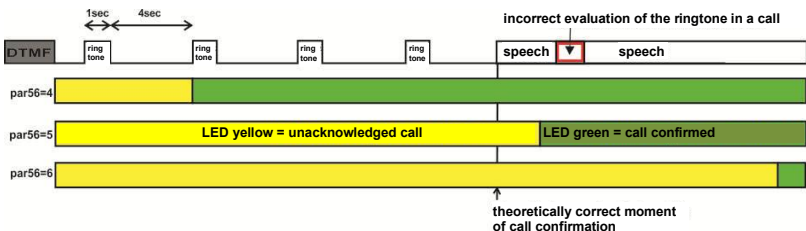

Parameter	Value	Description	Default
57	nd	Wait time for confirmation [sec] (10-99)	25

nd – 10 ÷ 99 sec is the timeout for a manual call confirmation after the call is picked-up.

If the call is confirmed within this period (**nd** – measured from the moment the call is answered) using the confirmation code (par. **47-40, 07**), the connection continues. If the confirmation is not received within the **nd** time limit, the call is terminated. The unit then proceeds either by dialing the next number or by repeating the call, depending on the call type.

The purpose of this parameter is to shorten the overall calling cycle. For example, if the maximum call duration is set to 4 minutes (par. **51**) and no one answers the called number, then in a mode without call confirmation the next number is dialed only after 4 minutes. In contrast, in a mode with call confirmation, the next number is dialed after the **nd** period, e.g., after 25 seconds. This significantly accelerates the process of reaching assistance from the lift cabin.

Parameter	Value	Description	Default
58	dd	Number of ringtones before hanging up (04-99)	12

dd – after the end of the dial, device counts the number of ringtones. If the number is greater than **dd**, so it hangs up and the dialing sequence continues [range 04-99].

Parameter	Value	Description	Default
59	dd	Period for making service calls (01-59)	03

dd – [01 ÷ 59 days] Period for making a service call in days

The number of hours to next service call can be displayed in the PC program LiftConfigurator. Before service call takes place (turns on par. **31**) it is also possible to check the acoustic path (the par. **019**)

Parameter	Value	Description	Default
5*	dd	Overcoming the blocking of the CABIN button (03-30)	30

dd – the time it takes to overcome the blocking of the CABIN button triggered by the BLK input status

Parameter	Value	Description	Default
5#	dd	Block an emergency call with a timer (00-99)	00

dd – for **dd** from change to active state (see parameter **34** on p. 46) on the BLK input, the CABIN button is blocked

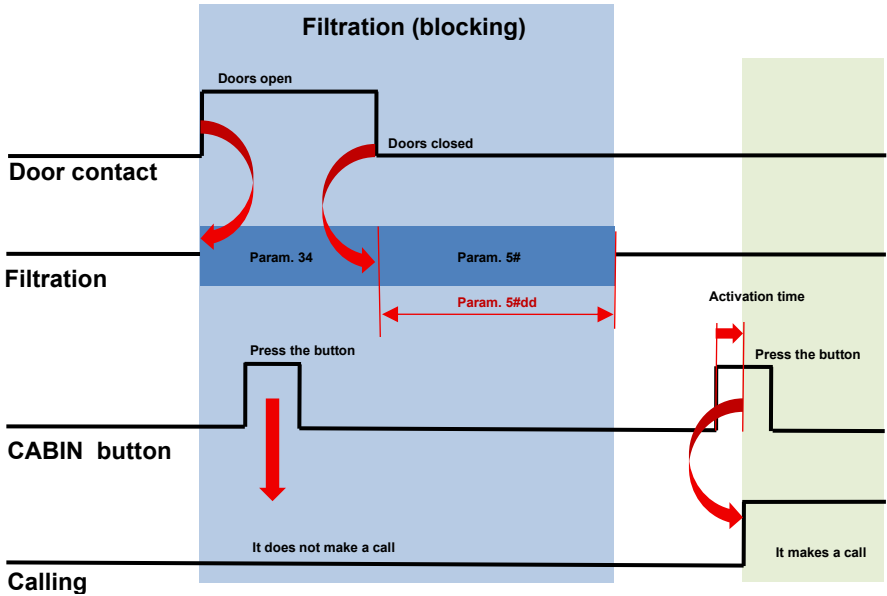

The **dd time** can be set, for example, to the time it takes for the elevator car to travel from the lowest floor to the top floor.

Parameter	Value	Meaning	Default
500	d	Mid tone detector frequency (1-0)	3 (375-475Hz)

d – medium frequency of the tone detector – set in the case of non-standard signaling of the phone system / PBX:

frequency [Hz]	k - Option
275-375	1
325-425	2
375-475	3
425-525	4
475-575	5
525-625	6
575-675	7
625-725	8
675-775	9
725-825	0

Parameter	Value	Meaning	Default
501	d	Number of busy tones (2-0)	4

d – Minimum number of busy tones required for detection [2-0], where 0 means 10 busy tones (i.e., two to ten)

Parameter	Value	Meaning	Default
502	n	Continuous tone duration (1-5)	3 (3s)

n – minimum duration of continuous tone (for detection of dial tone on PBX) [1-5 sec]

Parameter	Value	Meaning	Default
503	dd	DTMF tone duration (04..16)	10 (100ms)

dd – The duration of the DTMF tone is determined by the formula:
(number entered) x 10 = tone duration [ms] - [04-16 i.e. 40-160ms]

Parameter	Value	Meaning	Default
504	dd	DTMF space duration (04-16)	10 (100ms)

dd – The duration of the space between the DTMF tones is determined by the formula:
(number entered) x 10 = space duration [ms] - [04-16 i.e. 40-160ms]

Parameter	Value	Meaning	Default
506	d	Pause duration (1-0)	4 (800ms)

- d – The duration of the pause is determined according to the formula:
Entered number x 100 + 400 = pause duration [ms]
 [range 1-0 i.e. 500-1400ms]

4.5 System parameters

Parameter	Value	Meaning	Default
61	b	Acoustic signaling (acknowledgement, error, empty memory, end of call...) (0/1)	1

By default, the status of the communicator is signaled acoustically. The values are

- b=0** – the signaling is off
b=1 – the signaling is on

Parameter	Value	Meaning	Default
62	d	Acoustic signaling pick-up/hang-up (0/1/2)	1

By default, the pick-up and hang-up of the line is acoustically signaled, but this may cause false dialing or a change in the operating mode for some types of phone system / PBX.

- d=0** – pick-up and hang-up signaling is off
d=1 – pick-up and hang-up signaling switched on (Type1)
d=2 – pick-up and hang-up signaling switched on (Type2)

Parameter	Value	Meaning	Default
63	b	Ticking into a call (0/1)	0

By default, ticking into a call is turned off. By turning on this signaling, it is possible to distinguish the call exchange from the communicator by the weak regular ticking in the call. The values are

- b=0** – ticking into the call is off
b=1 – Ticking into a call turned on

Parameter	Value	Description	Default
64	c	Mute for special call types, turn on the microphone after confirming a call (0 - 7)	0

By default, mute is turned off for special types of calls and the microphone is still active – **c=0**.

For specific call types, it is possible to suppress audio (mute mode) during call setup for calls that are not intended for voice communication. When this parameter is enabled (**c=2, c=6**), the speaker volume is set to the lowest level during dialing so that DTMF tones do not disturb passengers inside the lift cabin. This function applies to the following special call types:

1. Service calls
2. Technical calls
3. Error calls

Another function of this parameter is to turn off the microphone until the call is confirmed (in simple terms, until the green LED lights up, the microphone is turned off, otherwise not - see the green LED function and call confirmation). This function will facilitate communication between the call center and communicators in a noisy environment - it is active at the value **c=4, c=6**.

When selecting this function (microphone off), it is possible to choose to extend the time after confirming the call, when the microphone is activated. Delaying the activation of the microphone after receiving a confirmation tone (i.e. with the green LED lit) will allow additional codes to be received from the CallCentrum and thus improve reliability.

Microphone activated:

- immediately after confirming the call **c = 4, 6**
- 3 sec after confirmation **c = 8.9**
- 6 sec after confirmation **c = *, #**

	Silence for special calls turned Off		Silence for Special Calls On	
	Microphone always active	Microphone activated after confirming a call	Microphone always active	Microphone activated after confirming a call
Value of c	0	4 [+0sec]	2	6 [+0sec]
	-	8 [+3sec]	-	9 [+3sec]
	-	* [+6sec]	-	# [+6sec]

Parameter	Value	Description	Default
65	b	BabyCall – call without the need to program a phone number (0/1)	0

By default, **b=0** is off. Turning on the **b=1** function cancels the acoustic signaling of empty memory and after pressing the button with empty memory, only a beep (confirmation) is heard and the call is made as if a number had been dialed.

Attention: the tone detector is not active for the first 10 seconds of the call (waiting for the phone system / PBX to react and dial the number by the phone system / PBX)

Parameter	Value	Description	Default
6*	b	Delayed start for PBX with line test (0/1)	0

By default, **b=0 is off**. By turning on the **b=1 function**, the communicator will immediately go to sleep after connecting the line, and after 5 seconds will the communicator be initialized. This will delay the pick-up of the line immediately after the voltage is connected – the moment when the phone system / PBX is restarting or switched on.

4.6 HandsFree Setup



First of all, make sure that the sealing foam around the microphone and speaker is functional, otherwise there may be a whistle or whizz from the acoustic feedback. It is important that the microphone and speaker have the best possible separation from each other.

The ForesLift Compact communicator uses potentiometers for adjusting the speaker volume and microphone sensitivity.

4.7 Bit parameters and power supply

Parameter	Value	Description	Default
011	b	Mode EN81-28 (b=0/1)	1

b=0 off – The Alarm status (yellow LED on) lasts only until the call is acknowledged, when the green LED lights up.

b=1 on – This is the **EN81-28:2022 mode**. The Alarm status (yellow LED on) is initiated by pressing the CABIN or SHAFT button and continues even after the call ends. It can be terminated either by a technician from the elevator car or by a confirmation code – see parameter **48** (default *67)

Parameter	Value	Description	Default
012	b	The ALARM state is terminated at the end of the call (b=0/1)	0

b=0 off

b=1 on – if parameter 011=1, the ALARM status is terminated automatically by ending the call, otherwise parameter **012** does nothing.

This feature is not implemented in the current firmware.

Parameter	Value	Description	Default
019	b	Turn on acoustic path testing (0/1)	0

b – 0 off

- 1 Acoustic path testing turned on. The acoustic path test is triggered by the service call function (par. **31**) with the same testing interval as for service calls (par. **59**). If you use a parameter confirmation code **07** the acoustic path test is performed immediately if the service call (par. **31**) and the acoustic path test (par. **019**) are enabled.

If the result of the acoustic test is incorrect, an error call with the code "0" is made.

Note 1: - if more microphones and speakers are used (in the cabin, above the cabin, under the cabin...), then not all acoustic paths may be tested, but it will be found that at least one path is functional.

Note 2: - the acoustic test depends on the environmental conditions (noise, talking, etc.), so the result may not be correct and there may be a call announcing an error and still everything is fine (it is enough if someone is talking in the cabin or the fan is running during the test...).

Parameter	Value	Description	Default
01*	b	Stuck button test	(0/1) 0

b – 0 off

- 1 on – After the end of any call, the communicator checks that the CABIN, SHAFT buttons are still pressed. If the BLK input is used to indicate the presence of a technician (param **34=4**), its state is also tested. The communicator knows the state of the disconnected button from the polarity setting. If this state is different, then the button (input) is faulty. Then an error call with code "7" is made. **The communicator is still functional, receiving calls and making service calls.**

 **Be careful** with the polarity setting of the CABIN button, if the setting is wrong, the button behaves as if it is permanently closed and the communicator will not respond correctly when pressed.

4.8 Presetting basic values, deleting

Parameter	Value	Meaning	Default
8##		Default settings	Only 0..,3..-7..

These settings do not affect parameters 1 and 2 (stored numbers in memory)

Parameter	Value	Meaning	Default
81		Erase all emergency phone numbers	Only 1..
82		Erase all other phone numbers	Only 2..
83		Default settings for 3x parameters only	Only 3..
84		Default settings for 4x parameters only	Only 4..
85		Default settings for 5x parameters only	Only 5..
86		Default settings for 6x parameters only	Only 6..
87		Default settings for 7x parameters only	Only 7..
80		Default settings for 0x parameters only	Only 0..

Parameters 81 and 82 erase all numbers stored in the button memories. Parameters 83 to 87, 80 will perform default settings for parameters starting with 3, 4, 5, 6, 7, 0. The values of the default settings are listed for each parameter on the right – the "Default" column.

 **CAUTION !!** Deletion is irreversible.

4.9 End of programming

Parameter	Value	Description	Default
9		Exit programming mode	-

After selecting 9, the communicator immediately hangs up and restarts.

4.10 Overview of parameters

Meaning of the symbols in the table:

d – digits 0..9 – the range depends on the parameter

n – natural number 1..9 – the range depends on the parameter

b – bit value 0/1

c – character 0..9, #, * – the range depends on the parameter

Par.	Value	Description	Basic
1	nb cc...	Phone number cc in order n with confirmation b	-
21	b cc...	Phone number cc with confirmation b (service)	-
22	b cc...	Phone number cc with confirmation b (technical)	-
23	b cc...	Phone number cc with confirmation b (error)	-
31	d	Service call state (0/1/2)	0
32	d	Service call retry time [min] (0..9)	4
33	b	Polarity of the CABIN button (in the cabin) (0/1)	0
34	d	Polarity of the BLK input (0/1/2)	0
35	n	Number of emergency calls redials (1-9)	3
36	n	Number of technical calls redials (1-9)	1
37	n	Number of error call redials (1-9)	1
38	dd	Number of service call redials (00-99)	00
39	b	Polarity of the SHAFT button (0/1)	0
42	c	Call prolongation character (* / #)	*
43	cc	Command to hang up the communicator from the phone (00-99,*0-*9)	44
44	dddd	Service password (0000-9999)	0000
45	b	Turn on parallel mode (0/1)	0
46	n	Number of rings before the communicator picks up / communicator number in parallel mode (1-5)	3
47	dddd	Confirmation code – the communicator returns the serial number (0-9999)	66
48	dddd	Confirmation code – the communicator ends the ALARM state) (0-9999)	67
49	dddd	Confirmation code – the communicator hangs up and makes an emergency call as if the CABIN button was pressed (0-9999)	68

40	dddd	Confirmation code – the communicator returns the last two called phone numbers (0-9999)	69
4*	dd	Constant for parallel mode – time to receive DTMF address of the communicator (10-49)	25
4#	c	The first common character of confirmation codes (0-9,*,#)	*
51	c	Maximum call duration [min] (0-9,*,#)	4
52	dd	Time to hold the SHAFT button to initiate an emergency call (01-30)	02
53	dd	Time to hold the CABIN button for initiating an emergency call (01-30)	05
54	n	Hangup time during redial (1-5)	2
55	n	Time before dialing a phone number (1-5)	1
56	d	Time without ringtone – automatic call confirmation (1-0)	5
57	nd	Wait time for confirmation [sec] (10-99)	25
58	dd	Number of ringtones before hanging up (04-99)	12
59	dd	Period for making service calls [days] (01-59)	03
5*	dd	Overcoming the blocking of the CABIN button (03-30)	30
5#	dd	Block an emergency call with a timer (00-99)	01
500	d	Mid tone detector frequency (1-0)	3 (375-475Hz)
501	d	Number of busy tones (2-0)	4
502	n	Continuous tone duration (1-5)	3 (3s)
503	dd	DTMF tone duration (04-16)	10 (100ms)
504	dd	DTMF space duration (04-16)	10 (100ms)
506	d	Pause duration (1-0)	4 (800ms)
61	b	Acoustic signaling (acknowledgement, error, empty memory, end of call...) (0/1)	1
62	d	Acoustic signaling pick-up/hang-up (0/1/2)	1
63	b	Ticking into a call (0/1)	0
64	c	Mute for special call types, turn on the microphone after confirming a call (0 – 9, *, #)	0
65	b	BabyCall - call without the need to program a phone number (0/1)	0
6*	b	Delayed start for PBX with line test (0/1)	0

011	b	Mode EN81-28 (b=0/1)	1
012	b	The ALARM state is terminated at the end of the call (b=0/1)	0
019	a	Turn on acoustic path testing (0/1)	0
01*	b	Stuck button test (0/1)	0
07	dddd	Confirmation code – the communicator hangs up and makes a service call (may include an acoustic path test) (0-9999)	65
8##		Set communicator to default settings	Only 0..,3..-7..
81		Erase all emergency phone numbers	Only 1..
82		Erase all other phone numbers	Only 2..
83		Default settings for 3x parameters only	Only 3..
84		Default settings for 4x parameters only	Only 4..
85		Default settings for 5x parameters only	Only 5..
86		Default settings for 6x parameters only	Only 6..
87		Default settings for 7x parameters only	Only 7..
80		Default settings for 0x parameters only	Only 0..
9		Exit programming mode	-

5. Quick guide for programming the communicator

- For error-free and complete programming, you need to know:
 - **PBX extension number used to connect the communicator**
 - **Telephone numbers** of the service organization (elevator supervisor, concierge, maintenance, service company)
- **Using a telephone with tone (DTMF) dialing** (analogue telephone in the building connected to a PBX exchange, mobile phone...) **Dial the phone number of the communicator. Or pick up an analog phone connected to the SwitchBoard in the engine room.**

Entering programming and putting it into a defined state:

- **#0000** after a while, a beep-beep starts to sound
- **8##** setting parameters to factory values (set all parameters except the phone numbers)
- **81** deletes emergency numbers
- **82** deletes service, technical and error call numbers

To set the 1st phone number for emergency calls (Alarm) without confirmation:

- **110 xxxxxx** and wait for confirmation with a longer beep. xxxxxx is the number to be dialed.

To set the 2nd phone number for emergency calls (Alarm) without confirmation:

- **120 xxxxxx** and wait for confirmation with a longer beep. xxxxxx is the number to be dialed.

Set up service calls for automatic functional verification

- Set up a phone number for periodic service calls
 - **210 yyyyyy** and wait for confirmation
- Set the service call period
 - **59 xx** where xx is the service call period in days ranging from 01 to 99
 - **311** Service calls are allowed and will be made according to the specified period

To exit programming mode:

- **9** or by hanging up the handset
- **Other parameters can be changed in accordance with the manual (see p. 66)**
- Test the functionality of the device

6. Technical parameters

6.1 Electrical Parameters

Parameter	Value	Terms and Conditions
Minimum line current	24 mA	Picked up line
Minimum line voltage	18 V	Hung-up line
Voltage on the line when picking up the communicator	>8 V	I = 25 mA
Bandwidth	300 Hz – 3400 Hz	20 – 60 mA
Ringer Detector Sensitivity	min. 10 – 25 V	
Tone Dial Sensitivity	min. -33 dB	20 – 60 mA
Internal speaker – impedance	50 Ω	
Speaker above / below the cab – impedance	50 Ω	
Microphone (inner, external above/below the booth)	electret, 2.2 k Ω , 38 dB	
Max. output current for LED Green and LED Yellow ¹	<100 mA	at U < 24 V
Operating Temperature	- 20 to + 50°C	

6.2 Mechanical parameters

Parameter	Value
Dimensions W x D x H	85 x 114 x 31 [mm] (box) 96 x 133 x 37 [mm] (incl. handles and connectors)
Mounting holes (2pcs)	for M3 or M4 screw

¹The current must always be limited by a suitable resistor connected in series with the LED; otherwise, the output will be damaged and the warranty will be void.



Alphatech spol. s r. o. company declares under its sole responsibility that the product is in compliance with the common requirements and other related EU regulations. The original statement can be found at www.alphatech.cz.eu/en in the Support section.



Do not contaminate the environment, make sure that the packaging material will be disposed of in accordance with applicable laws and regulations. At the end of its life, it is necessary to ensure environmentally friendly disposal. It is recommended to recycle the separated parts. Components to be recycled are marked with the recycling symbol and the symbol of the specific material.



Alphatech spol. s r. o.
Jeremenkova 88
140 00 Prague 4-CZ
tel. +420 244 461 072

E-mail: info@alphatech.cz
Internet: www.alphatech.cz
our GPS coordinates (WGS 84)
N 50°02'35.5" E 14°25'42.0"